



GEARBOX CATALOGUE

Quality. Service. Range



TJA SERIES

Single Stage Inline Helical

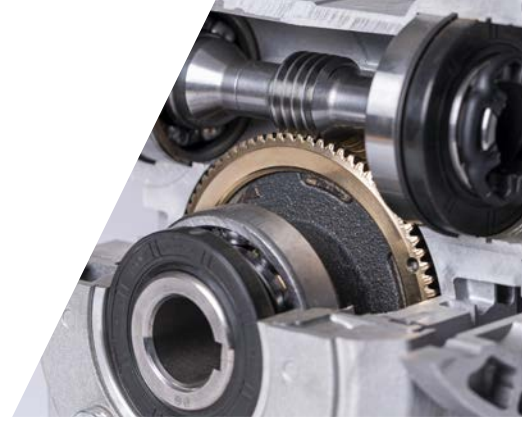

The story of Techtop Australia

A business that's powered by people.

Techtop Australia Pty Ltd, founded by well-respected Directors Rohan Pollard and Jeff Aird, entered a joint venture partnership in 2013 with Shanghai Top Motor Co, the largest manufacturer of aluminium electric motors in China.

In 2015, Jack Gringlas OAM joined the board of Techtop Australia as Chairman, the board comprising these 3 directors have knowledge of the Australian electric motor market spanning back over 40 years.

The combination of a leading motor manufacturer and Australia's most experienced sales team provides our customers with quality products, excellent service & technical knowledge.









Techtop Australia will now form part of a global organisation with Techtop's leading partners in America, Canada, Europe & U.A.E. just to mention a few.

Techtop Australia Pty Ltd, has its head office and primary distribution operation based in Dandenong, an outer eastern suburb of Melbourne.

Since our inception we have opened sales offices and warehouses in every mainland state of Australia and are now the only company that can provide direct representation in these 5 locations; Melbourne, Sydney, Brisbane, Adelaide & Perth. Each of these offices has a local manager that enjoys many years' experience in the industry and is respected by our wide and diverse customer base.

The company's strength is based on it's professional, experienced and enthusiastic staff, who are constantly striving to ensure customer service is held at the forefront of our business.

In addition to the gearbox range covered in this catalogue, we are proud to offer the widest range of related products available in the industry today, some of these are detailed below.

-  Varvel Gearboxes
-  Single Stage Helical Gearboxes
-  Stainless Steel Gearboxes
-  VVVF Drives
-  ECM Variable Speed Motor
-  Stainless Steel Motors
-  Shaded Pole Motors

CONTENTS



	Page
INTRODUCTION	4
PART NUMBER LOGIC	4
GEARBOX SELECTION	5
TJA1 SERIES SELECTION DATA	6 - 8
TYPE OF COMBINATION	9
WEIGHTS	9
DIMENSION DRAWINGS & DATA	
Foot Mount	10
Flange Mount	11
INSTALLATION & MAINTENANCE	12
LUBRICATION	13
LUBRICATION POINTS	
Foot Mount	14
Flange Mount	15

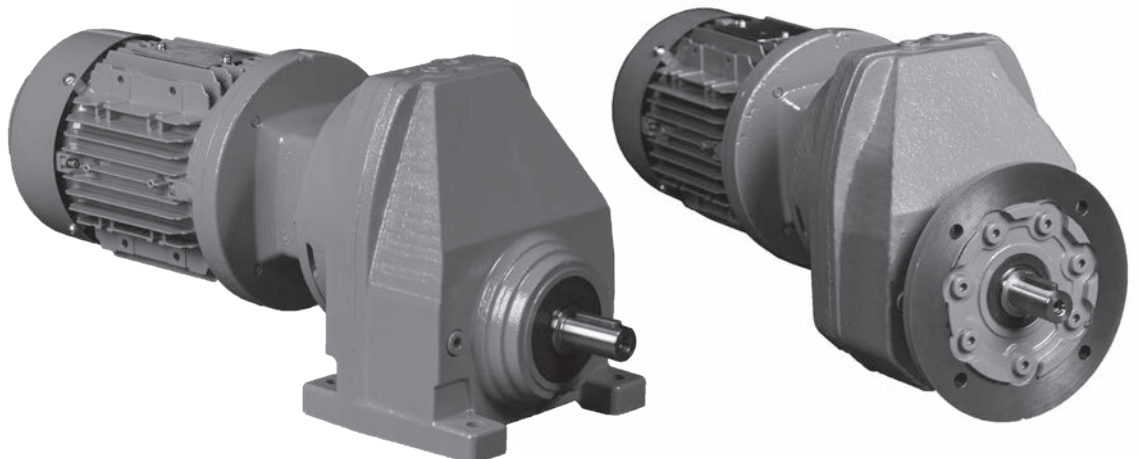

INTRODUCTION

Helical Geared Motors, Reducers, Variable Speed Drives

The comprehensive Techtop range of transmission products includes both Varvel's range of industrial gearboxes, Mechanical Friction Disc and Planetary Variable Speed Drives, along with the VarSpe Hydrostatic Variator.

In addition to this, Techtop's new helical single stage range covers 0.09kW through 45.0kW input power, with an output torque capacity of up to and including 3,360NM in foot or flange mount, available for use in many mounting positions.

Incorporated in Techtop's Transmission product is the utilization of Techtop's standard shaft and flange mounted motors to Australian standard AS/NZS 1359 and international standards, IEC 60034 & IEC 60072.

The gearboxes can also be fitted with brake, 2 speed, single phase and D.C. motors. Additional options such as clutch/brake, anti run back bearings, external cooling fans are available, contact your nearest Techtop Australia office.

The flexibility of design enables motor/gearbox units to be changed in kW rating if required provided the maximum torque capacity of the gearbox is not exceeded.

By incorporating standard metric flange mount motors in our products, this enables rapid change if required, keeping down time to a minimum.

Efficiency

All helical geared unit efficiencies are determined by gearing and bearing friction. Efficiency ranges between 94% (3 stages) and 98% (Single Stage).

In addition to the standard features of the Techtop gearbox, we can design and manufacture locally, special shafts, output flanges or input connections upon request.

Part Number Logic

Detailed below is the part number logic which should be specified when placing orders. The part number is composed in accordance with the following example:

TJA	1	20	425	080	S
1-3	4	5-6	7-9	10-12	13

Position 1 to 3

Gearbox type = TJA

Position 4

No. of stages:

1 = single stage

Position 5 to 6

Model number = (output shaft diameter)

Position 7 to 9

Ratio

Position 10 to 12

Gearbox input size (IEC B5)

(071, 080, 090, 100, 112, 132, 160, 180, 200 or 225)

Position 13

Mounting type

Foot mount = S

Flange mount:

A = 120

B = 140

C = 160

D = 200

E = 250

F = 300

G = 350

H = 400

I = 450

GEARBOX SELECTION



Operating conditions decide the selection of the drive.

Before turning to the selection tables the appropriate service factor must be determined, taking into account the following points:

- ☛ Type of driven machine
- ☛ Required power (kW) or torque (Nm)
- ☛ Total operational hours per day
- ☛ Reversing
- ☛ Shock loading
- ☛ Input and output speeds
- ☛ Mounting arrangement

DAILY OPERATION IN HOURS	8 HOURS			16 HOURS			24 HOURS		
	10	10-200	200	10	10-200	200	10	10-200	200
STARTS PER HOUR									
Light Duty Cycle	0.9	1	1.1	1	1.1	1.2	1.0	1.2	1.4
Medium Duty Cycle	1.0	1.1	1.3	1.1	1.3	1.5	1.3	1.5	1.6
Heavy Duty Cycle	1.3	1.4	1.6	1.5	1.6	1.7	1.6	1.7	1.8

Load Classification - Driven Machine

Uniform/Light Duty Cycle

Mass acceleration factor ≤ 0.3

Generators, belt conveyors, platform conveyors, screw conveyors, auxiliary machine tool drives, agitators and mixers for light uniform density materials.

Moderate Shock/Medium Duty Cycle

Mass acceleration factor ≤ 3

Main machine tool drives, hoists, slewing gear, cranes, induced draught fans, mixer and agitators for materials with variable density, multi-cylinder piston pumps, metering pumps, elevators.

Heavy Shock/Heavy Duty Cycle

Mass acceleration factor ≤ 10

Punch presses, shears, Banbury mixers, rolling mill and foundry drives, bucket dredger, heavy centrifugal drives, heavy metering pumps, rotary drilling equipment, briquet presses, pug mills.

TJA1 SERIES SELECTION DATA



Type	r/min	Nm	SF	Ratio	Gearbox code	Overhung Load
0.37kW	Motor 71B-4 code TA4A0375TAI 1370 r/min 1.03 Amps					
TJA1 20-71B	830	4.3	16.00	1.65	TJA120165071*	2240
	714	5	14.00	1.92	TJA120192071*	2350
	672	5.3	13.00	2.04	TJA120204071*	2400
	578	6.1	11.00	2.37	TJA120237071*	2520
	519	6.8	10.00	2.64	TJA120264071*	2610
	471	7.5	8.90	2.91	TJA120291071*	2690
	436	8	8.10	3.14	TJA120314071*	2760
	386	9	7.60	3.55	TJA120355071*	2870
	361	10	7.10	3.79	TJA120379071*	2930
	315	11	6.10	4.35	TJA120435071*	3060
	270	13	2.80	5.07	TJA120507071*	3210
	249	14	2.80	5.50	TJA120550071*	3300

Type	r/min	Nm	SF	Ratio	Gearbox code	Overhung Load
0.55kW	Motor 80A-4 code TA4A0555TAI 1410 r/min 1.6 Amps					
TJA1 20-80A	1085	4.8	13.00	1.30	TJA120130080*	2070
	953	5.5	12.00	1.48	TJA120148080*	2150
	855	6.1	11.00	1.65	TJA120165080*	2230
	734	7.2	9.30	1.92	TJA120192080*	2350
	691	7.6	8.70	2.04	TJA120204080*	2390
	595	9	7.50	2.37	TJA120237080*	2510
	534	10	6.80	2.64	TJA120264080*	2600
	485	11	6.00	2.91	TJA120291080*	2680
	449	12	5.40	3.14	TJA120314080*	2740
	397	13	5.00	3.55	TJA120355080*	2850
	372	14	4.70	3.79	TJA120379080*	2910
	324	16	4.10	4.35	TJA120435080*	3040
TJA1 25-80A	311	17	3.80	4.53	TJA125453080*	3800
	272	19	4.70	5.18	TJA125518080*	3970

Type	r/min	Nm	SF	Ratio	Gearbox code	Overhung Load
0.75kW	Motor 80B-4 code TA4A0755TAI 1420 r/min 1.94 Amps					
TJA1 20-80A	1092	6.6	9.30	1.30	TJA120130080*	2050
	959	7.5	8.80	1.48	TJA120148080*	2130
	861	8	8.00	1.65	TJA120165080*	2210
	740	10	6.90	1.92	TJA120192080*	2310
	696	10	6.50	2.04	TJA120204080*	2360
	599	12	5.60	2.37	TJA120237080*	2470
	538	13	5.00	2.64	TJA120264080*	2560
	488	15	4.40	2.91	TJA120291080*	2630
	452	16	4.00	3.14	TJA120314080*	2700
	400	18	3.80	3.55	TJA120355080*	2800
	375	19	3.50	3.79	TJA120379080*	2860
	326	22	3.90	4.35	TJA120435080*	2980
TJA1 25-80A	313	23	2.80	4.53	TJA125453080*	3750
	274	26	3.50	5.18	TJA125518080*	3900

Type	r/min	Nm	SF	Ratio	Gearbox code	Overhung Load
1.1kW	Motor 90S-4 code TA4B0115TAI 1420 r/min 2.6 Amps					
TJA1 20-90S	1092	10	6.40	1.30	TJA120130090*	2010
	959	11	6.10	1.48	TJA120148090*	2090
	861	12	5.60	1.65	TJA120165090*	2160
	740	14	4.80	1.92	TJA120192090*	2270
	696	15	4.50	2.04	TJA120204090*	2310
	599	18	3.90	2.37	TJA120237090*	2420
	538	20	3.50	2.64	TJA120264090*	2500
	488	22	3.10	2.91	TJA120291090*	2570
	452	23	2.80	3.14	TJA120314090*	2630
	400	26	2.60	3.55	TJA120355090*	2730
	375	28	2.40	3.79	TJA120379090*	2780
TJA1 25-90S	330	32	2.50	4.30	TJA125430090*	3610
	313	34	2.40	4.53	TJA125453090*	3660
TJA1 30-90S	300	35	3.50	4.73	TJA130473090*	5380
	265	40	2.60	5.35	TJA130535090*	5590
	252	42	2.60	5.63	TJA130563090*	5680

Type	r/min	Nm	SF	Ratio	Gearbox code	Overhung Load
1.5kW	Motor 90L-4 code TA4B0155TAI 1440 r/min 3.4 Amps					
TJA1 20-90S	1108	13	4.70	1.30	TJA120130090*	1980
	973	15	4.50	1.48	TJA120148090*	2050
	873	16	4.10	1.65	TJA120165090*	2120
	750	19	3.50	1.92	TJA120192090*	2220
	706	20	3.30	2.04	TJA120204090*	2260
	608	24	2.90	2.37	TJA120237090*	2360
	545	26	2.60	2.64	TJA120264090*	2440
	495	29	2.30	2.91	TJA120291090*	2510
	459	31	2.00	3.14	TJA120314090*	2560
	406	35	1.90	3.55	TJA120355090*	2650
	380	38	1.80	3.79	TJA120379090*	2700
TJA1 25-90S	335	43	1.85	4.30	TJA125430090*	3520
	318	45	1.80	4.53	TJA125453090*	3570
TJA1 30-90S	304	47	2.90	4.73	TJA130473090*	5300
	269	53	1.90	5.35	TJA130535090*	5490
	256	56	1.90	5.63	TJA130563090*	5580

Type	r/min	Nm	SF	Ratio	Gearbox code	Overhung Load
2.2kW	Motor 100LA-4 code TA4B0225TAI 1440 r/min 4.6 Amps					
TJA1 20-100LA	1108	19	3.30	1.30	TJA120130100*	1930
	973	22	3.10	1.48	TJA120148100*	1990
	873	24	2.80	1.65	TJA120165100*	2060
	750	28	2.40	1.92	TJA120192100*	2150
	706	30	2.30	2.04	TJA120204100*	2190
	608	35	1.95	2.37	TJA120237100*	2280
	545	39	1.75	2.64	TJA120264100*	2340
	459	46	1.40	3.14	TJA120314100*	2450
TJA1 25-100LA	450	47	2.10	3.20	TJA125320100*	3130
	382	55	1.55	3.77	TJA125377100*	3280
TJA1 30-100LA	356	59	2.40	4.04	TJA130404100*	4950
	304	69	1.75	4.73	TJA130473100*	5180



Type	r/min	Nm	SF	Ratio	Gearbox code	Overhung Load
3.0kW	Motor 100LB-4 code TA4B0305TAI 1445 r/min 6.3 Amps					
TJA1 20-100LB	1112	26	2.40	1.30	TJA120130100*	1870
	976	29	2.30	1.48	TJA120148100*	1930
	876	33	2.00	1.65	TJA120165100*	1990
	753	38	1.75	1.92	TJA120192100*	2070
	708	40	1.65	2.04	TJA120204100*	2100
	610	47	1.40	2.37	TJA120237100*	2180
	547	54	1.30	2.64	TJA120264100*	2240
	460	62	1.00	3.14	TJA120314100*	2330
TJA1 25-100LB	452	63	1.55	3.20	TJA125320100*	3030
	383	75	1.15	3.77	TJA125377100*	3150
TJA1 30-100LB	358	80	1.75	4.04	TJA130404100*	4830
	305	94	1.25	4.73	TJA130473100*	5050

Type	r/min	Nm	SF	Ratio	Gearbox code	Overhung Load
4.0kW	Motor 112M-4 code TA4B0405TAI 1440 r/min 8.2 Amps					
TJA1 20-112M	1108	34	1.80	1.30	TJA120130112*	1790
	973	39	1.70	1.48	TJA120148112*	1840
	873	44	1.55	1.65	TJA120165112*	1900
	750	51	1.35	1.92	TJA120192112*	1940
	706	54	1.25	2.04	TJA120204112*	1910
	608	63	1.10	2.37	TJA120237112*	1780
	545	71	0.95	2.64	TJA120264112*	1670
TJA1 25-112M	706	54	2.40	2.04	TJA125204112*	2580
	600	64	1.90	2.40	TJA125240112*	2690
	567	67	1.75	2.54	TJA125254112*	2730
	498	77	1.35	2.89	TJA125289112*	2810
	450	85	1.15	3.20	TJA125320112*	2870
TJA1 30-112M	443	86	2.10	3.25	TJA130325112*	4410
	389	98	1.55	3.70	TJA130370112*	4560
	356	107	1.30	4.04	TJA130404112*	4670

Type	r/min	Nm	SF	Ratio	Gearbox code	Overhung Load
5.5kW	Motor 132S-4 code TA4B0555TAI 1460 r/min 11.0 Amps					
TJA1 25-132S	1043	50	2.00	1.40	TJA125140132*	2220
	907	58	1.95	1.61	TJA125161132*	2300
	785	67	1.85	1.86	TJA125186132*	2380
	716	73	1.80	2.04	TJA125204132*	2430
	608	86	1.40	2.40	TJA125240132*	2520
	575	91	1.25	2.54	TJA125254132*	2550
TJA1 30-132S	685	77	2.60	2.13	TJA130213132*	3780
	601	87	2.40	2.43	TJA130243132*	3920
	541	97	2.20	2.70	TJA130270132*	4030
	474	111	1.70	3.08	TJA130308132*	4160
	449	117	1.50	3.25	TJA130325132*	4220
TJA1 40-132S	472	111	3.60	3.09	TJA140309132*	5460
	420	125	3.20	3.48	TJA140348132*	5640
	386	136	2.20	3.78	TJA140378132*	5770
	324	162	1.75	4.50	TJA140450132*	6040
TJA1 50-132S	401	131	4.40	3.64	TJA150364132*	7350
	361	145	4.00	4.04	TJA150404132*	7580
	323	163	3.60	4.52	TJA150452132*	7820
	297	177	2.20	4.91	TJA150491132*	8010
	252	208	1.95	5.79	TJA150579132*	8380

Type	r/min	Nm	SF	Ratio	Gearbox code	Overhung Load
7.5kW	Motor 132M-4 code TA4B0755TAI 1450 r/min 14.3 Amps					
TJA1 25-132M	1036	69	1.50	1.40	TJA125140132*	2080
	901	80	1.40	1.61	TJA125161132*	2060
	780	92	1.35	1.86	TJA125186132*	1930
	711	101	1.30	2.04	TJA125204132*	1810
	604	119	1.00	2.40	TJA125240132*	1610
TJA1 30-132M	771	93	2.00	1.88	TJA130188132*	3510
	681	105	1.85	2.13	TJA130213132*	3620
	597	120	1.75	2.43	TJA130243132*	3730
	537	133	1.60	2.70	TJA130270132*	3820
	471	152	1.25	3.08	TJA130308132*	3890
	446	161	1.10	3.25	TJA130325132*	3820
TJA1 40-132M	469	153	2.60	3.09	TJA140309132*	5260
	417	172	2.30	3.48	TJA140348132*	5420
	384	187	1.60	3.78	TJA140378132*	5530
	322	222	1.30	4.50	TJA140450132*	5760
TJA1 50-132M	398	180	3.30	3.64	TJA150364132*	7160
	359	200	2.90	4.04	TJA150404132*	3760
	321	223	2.60	4.52	TJA150452132*	7580
	295	243	1.60	4.91	TJA150491132*	7750
	250	286	1.45	5.79	TJA150579132*	8080

Type	r/min	Nm	SF	Ratio	Gearbox code	Overhung Load
11.0kW	Motor 160M-4 code TA4C1105TAI 1455r/min 21.3 Amps					
TJA1 40-160M	1047	100	2.90	1.39	TJA140139160*	4050
	909	116	2.70	1.60	TJA140160160*	4200
	754	139	2.50	1.93	TJA140193160*	4400
	677	155	2.50	2.15	TJA140215160*	4530
	587	179	2.20	2.48	TJA140248160*	4680
	527	199	2.00	2.76	TJA140276160*	4790
	471	223	1.80	3.09	TJA140309160*	4910
	418	251	1.60	3.48	TJA140348160*	5030
TJA1 50-160M	650	162	3.60	2.24	TJA150224160*	6000
	551	191	3.10	2.64	TJA150264160*	6280
	498	211	2.80	2.92	TJA150292160*	6440
	441	238	2.50	3.30	TJA150330160*	6640
	400	263	2.20	3.64	TJA150364160*	6800
	360	292	2.00	4.04	TJA150404160*	6970
	322	326	1.80	4.52	TJA150452160*	7150
TJA1 60-160M	313	336	2.10	4.65	TJA160465160*	8770
	280	375	1.85	5.19	TJA160519160*	9000

TJA1 SERIES SELECTION DATA

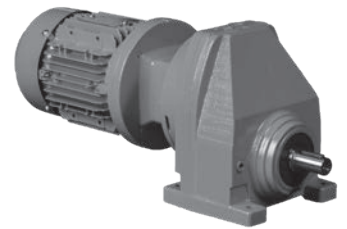

Type	r/min	Nm	SF	Ratio	Gearbox code	Overhung Load
15.0kW	Motor 160L-4 code TA4C1505TAI 1460 r/min 28.2 Amps					
TJA1 40-160M	1050	136	2.10	1.39	TJA140139160*	3840
	913	157	2	1.60	TJA140160160*	3960
	756	189	1.9	1.93	TJA140193160*	4130
	679	211	1.8	2.15	TJA140215160*	4230
	589	243	1.67	2.48	TJA140248160*	4350
	529	271	1.5	2.76	TJA140276160*	4430
	472	303	1.35	3.09	TJA140309160*	4510
	420	341	1.2	3.48	TJA140348160*	4260
TJA1 50-160M	553	259	2.30	2.64	TJA150264160*	5970
	500	287	2.10	2.92	TJA150292160*	6110
	442	324	1.85	3.30	TJA150330160*	6270
	401	357	1.65	3.64	TJA150364160*	6400
	361	396	1.50	4.04	TJA150404160*	6530
	323	443	1.35	4.52	TJA150452160*	6660
TJA1 60-160M	383	374	2.20	3.81	TRX600038160*	7930
	348	412	2.00	4.20	TJA160420160*	8100
	314	456	1.50	4.65	TJA160465160*	7260
	281	509	1.35	5.19	TJA160519160*	8440

Type	r/min	Nm	SF	Ratio	Gearbox code	Overhung Load
18.5kW	Motor 180M-4 code TA4C1805TAI 1460 r/min 33.2 Amps					
TJA1 40-180M	1050	168	1.75	1.39	TJA140139180*	2670
	913	194	1.65	1.60	TJA140160180*	3770
	756	234	1.55	1.93	TJA140193180*	3820
	679	260	1.50	2.15	TJA140215180*	3630
	589	300	1.35	2.48	TJA140248180*	3340
	529	334	1.20	2.76	TJA140276180*	3040
TJA1 50-180M	1028	172	2.70	1.42	TJA150142180*	4940
	890	198	2.60	1.64	TJA150164180*	5120
	745	237	2.40	1.96	TJA150196180*	5350
	652	271	2.20	2.24	TJA150224180*	5510
	553	319	1.85	2.64	TJA150264180*	5710
	500	353	1.70	2.92	TJA150292180*	5830
	442	399	1.50	3.30	TJA150331180*	5960
	401	440	1.35	3.64	TJA150364180*	6060
TJA1 60-180M	383	461	2.20	3.81	TJA160381180*	7580
	348	508	2.00	4.20	TJA160420180*	7710

Type	r/min	Nm	SF	Ratio	Gearbox code	Overhung Load
22.0kW	Motor 180L-4 code TA4C2205TAI 1460 r/min 39.4 Amps					
TJA1 40-180L	1050	200	1.75	1.39	TJA140139180*	3030
	913	230	1.65	1.60	TJA140160180*	2750
	756	278	1.55	1.93	TJA140193180*	2450
	679	309	1.25	2.15	TJA140215180*	2160
	589	357	1.15	2.48	TJA140248180*	1710
	529	397	1.00	2.76	TJA140276180*	1270
TJA1 50-180L	1028	204	2.20	1.42	TJA150142180*	4790
	890	236	2.20	1.64	TJA150164180*	4960
	745	282	2.00	1.96	TJA150196180*	5160
	652	322	1.85	2.24	TJA150224180*	5300
	553	380	1.55	2.64	TJA150264180*	5460
	500	420	1.40	2.92	TJA150292180*	5560
	442	475	1.25	3.30	TJA150330180*	5650
	401	524	1.15	3.64	TJA150364180*	5720
TJA1 60-180L	432	486	1.70	3.38	TRX600033180*	7090
	383	548	1.50	3.81	TJA160381180*	7230
	348	604	1.40	4.20	TJA160420180*	7330

Type	r/min	Nm	SF	Ratio	Gearbox code	Overhung Load
30.0kW	Motor 200L-4 code TA4C3005TAI 1470 r/min 54.2 Amps					
TJA1 50-200L	1035	203	1.65	1.42	TJA150142200*	4450
	896	320	1.60	1.64	TJA150164200*	4580
	750	382	1.50	1.96	TJA150196200*	4450
	656	437	1.35	2.24	TJA150224200*	4050
	557	515	1.15	2.64	TJA150264200*	3560
	503	569	1.05	2.92	TJA150292200*	3120
TJA1 60-200L	1021	281	2.30	1.44	TJA160144200*	5520
	860	333	2.10	1.71	TJA160171200*	5720
	754	380	2.00	1.95	TJA160195200*	5870
	639	448	1.85	2.30	TJA160230200*	6050
	557	515	1.60	2.64	TJA160264200*	6180
	479	598	1.40	3.07	TJA160307200*	6310
	435	659	1.25	3.38	TJA160338200*	6370

Type	r/min	Nm	SF	Ratio	Gearbox code	Overhung Load
37.0kW	Motor 225S-4 code TC4C3705TCI 1475 r/min 65.4 Amps					
TJA1 60-225S	1024	345	1.85	1.44	TJA160144225*	5220
	863	410	1.70	1.71	TJA160171225*	5370
	756	467	1.65	1.95	TJA160195225*	5490
	641	551	1.50	2.30	TJA160230225*	5610
	559	632	1.30	2.64	TJA160264225*	5530
	480	735	1.10	3.07	TJA160307225*	4950
	436	810	1.00	3.38	TJA160338225*	4470

Type	r/min	Nm	SF	Ratio	Gearbox code	Overhung Load
45.0kW	Motor 225M-4 code TC4C4505TCI 1475 r/min 85.1 Amps					
TJA1 60-225M	1024	420	1.55	1.44	TJA160144225*	4880
	863	498	1.40	1.71	TJA160171225*	4540
	756	568	1.35	1.95	TJA160195225*	4200
	641	670	1.25	2.30	TJA160230225*	3640
	559	769	1.10	2.64	TJA160264225*	2970
	480	894	0.90	3.07	TJA160307225*	2080
	436	985	0.85	3.38	TJA160338225*	1360



TYPE OF COMBINATION

The table below shows the compatibility between available ratio range and motor input adaptor.

Gear unit size	Stages	D71	D80	D90	D100	D112	D132S	D132M
TJA120	1	1.65-5.50	1.30-4.35	1.30-3.79	1.30-2.64 3.14	1.30-2.64	1.30-2.04	1.30-2.04
TJA125	1	2.04-6.07	1.61-5.18	1.40-4.53	1.40-3.77	1.40-3.20	1.40-2.54	1.40-2.54
TJA130	1	2.70-8.00	2.13-6.41	1.42-5.63	1.42-4.73	1.42-4.04	1.42-3.25	1.42-3.25
TJA140	1		3.09-8.65	2.15-7.63	1.60-6.45	1.60-5.56	1.39-4.50	1.39-4.50
TJA150	1		4.04-8.23	2.92-8.23	2.24-8.23	2.24-7.16	1.42-5.79	1.42-5.79
TJA160	1				2.64-6.63	2.64-6.63	1.71-6.63	1.71-6.63

Gear unit size	Stages	D160S	D160M	D160L	D180	D200	D225
TJA130	1	1.42-2.43	1.42-2.43				
TJA140	1	1.39-3.48	1.39-3.48	1.39-3.48	1.39-2.76		
TJA150	1	1.42-4.52	1.42-4.52	1.42-4.52	1.42-3.64	1.42-29.2	
TJA160	1	1.44-5.19	1.44-5.19	1.44-5.19	1.44-4.20	1.44-3.38	1.44-3.38

WEIGHTS

Weights as per table are in kgs and are indicated as follow: Gearbox Only / Geared Motor.

Weights for complete units include Techtop motors as detailed in the Selection Pages and are approximate only.

FOOT MOUNT WEIGHTS

Gear unit size	Stages	D71	D80	D90	D100	D112	D132S	D132M	D160S	D160M	D180L	D180M	D200	D225S	D225M
TJA120	1	15/21	19/30	19/37	20/46	20/55									
TJA125	1			22/40	23/49	23/58	34/84	34/97							
TJA130	1			32/50	33/60	33/68	45/94	45/107							
TJA140	1						63/112	63/125	76/159	76/178	79/198	79/208			
TJA150	1						92/141	92/154	108/191	108/210	109/228	109/238	126/295		
TJA160	1								141/224	141/243	144/263	144/273	159/328	169/484	169/519

FLANGE MOUNT WEIGHTS

Gear unit size	Stages	D71	D80	D90	D100	D112	D132S	D132M	D160S	D160M	D180L	D180M	D200	D225S	D225M
TJA120	1	17/23	21/32	21/39	22/48	22/57									
TJA125	1			26/44	27/53	27/62	38/88	38/101							
TJA130	1			34/54	37/64	37/72	49/98	49/111							
TJA140	1						68/117	68/130	81/164	81/183	81/203	81/213			
TJA150	1						99/148	99/161	115/198	115/217	116/235	116/245	133/302		
TJA160	1								156/239	156/258	159/278	159/288	174/343	184/499	184/533

DIMENSIONAL DRAWINGS

Foot Mounted

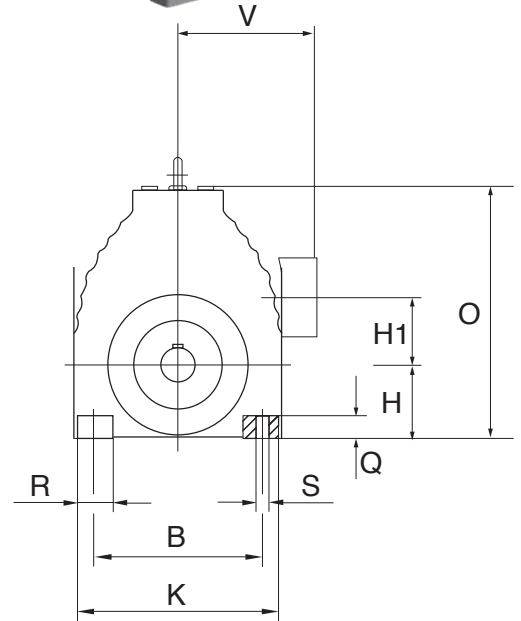
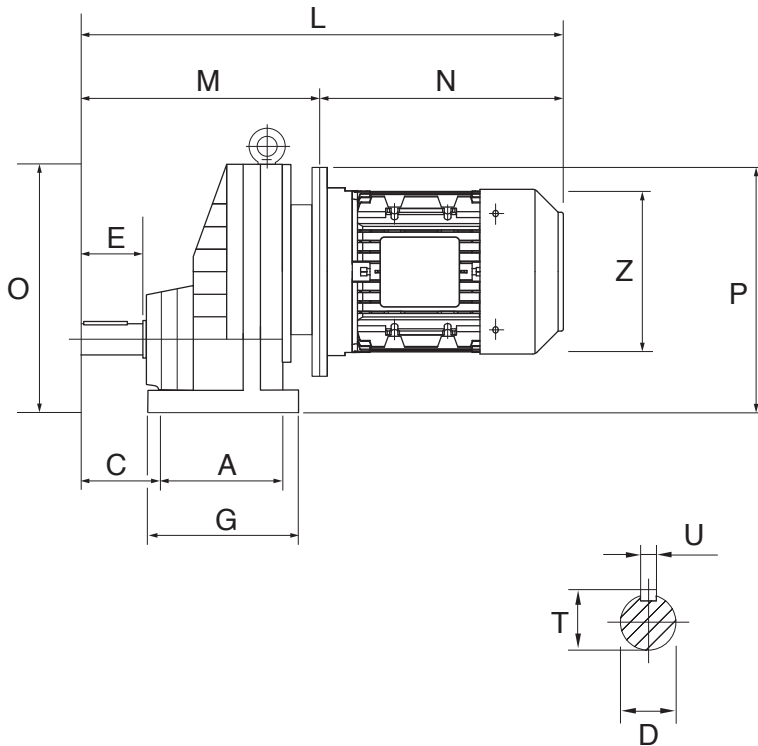
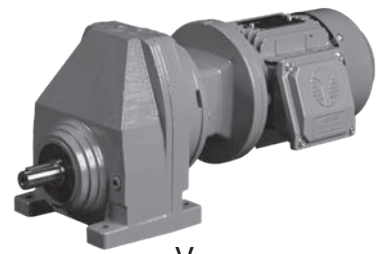

FOOT MOUNT DIMENSIONAL DATA

Sizes are in mm

Size	Frame	A	B	C	D	E	G	H	H1	K	L	M	N	O	P	Q	R	S	T	U	V	Z	
TJA120	D71 (1)										476	261	215		195							114	138
	D80 (1)										527	287	240		215							134	158
	D90 (1)	110	125	56	20 k6	40	137	63	52	156	577	287	290	202	215	18	31	11	22.5	6		143	177
	D100 (2)										635	318	317		240							160	200
	D112 (2)										658	318	340		240							171	220
TJA125	D90 (1)										604	314	290		240							143	177
	D100 (2)	120	135	75	25 k6	50	150	80	60	170	662	345	317	226	265	20	35	13.5	28	8		160	200
	D112 (2)										685	345	340		265							171	220
	D132 (2)										796	378	418		290							190	261
TJA130	D90 (1)										609	319	290		262							143	177
	D100 (2)	150	170	85	30 k6	60	190	90	72	204	680	363	317	271	287	25	50	17.5	33	8		160	200
	D112 (2)										703	363	340		287							171	220
	D132 (2)										841	423	418		312							190	261
TJA140	D132 (2)										878	460	418		343.5							190	261
	D160 (2)	160	215	110	40 k6	80	206	100	93.5	266	1057	505	552	332	368.5	30	60	17.5	43	12		231	313
	D180 (2)										1125	505	620		368.5							260	368
TJA150	D132 (2)										920	502	418		378							190	261
	D160 (2)	185	250	140	50 k6	100	240	112	116	320	1099	547	552	393	403	35	70	22	53.5	14		231	313
	D180 (2)										1167	547	620		403							260	368
	D200 (2)										1219	584	635		428							260	368
TJA160	D160 (2)										1141	589	552		445							231	313
	D180 (2)	210	310	152	60 m6	120	260	140	130	360	1209	589	620	459	445	45	80	22	64	18		260	368
	D200 (1)										1261	626	635		470							260	368
	D225 (2)										1331	661	670		495							332	465

DIMENSIONAL DRAWINGS

Flange Mounted

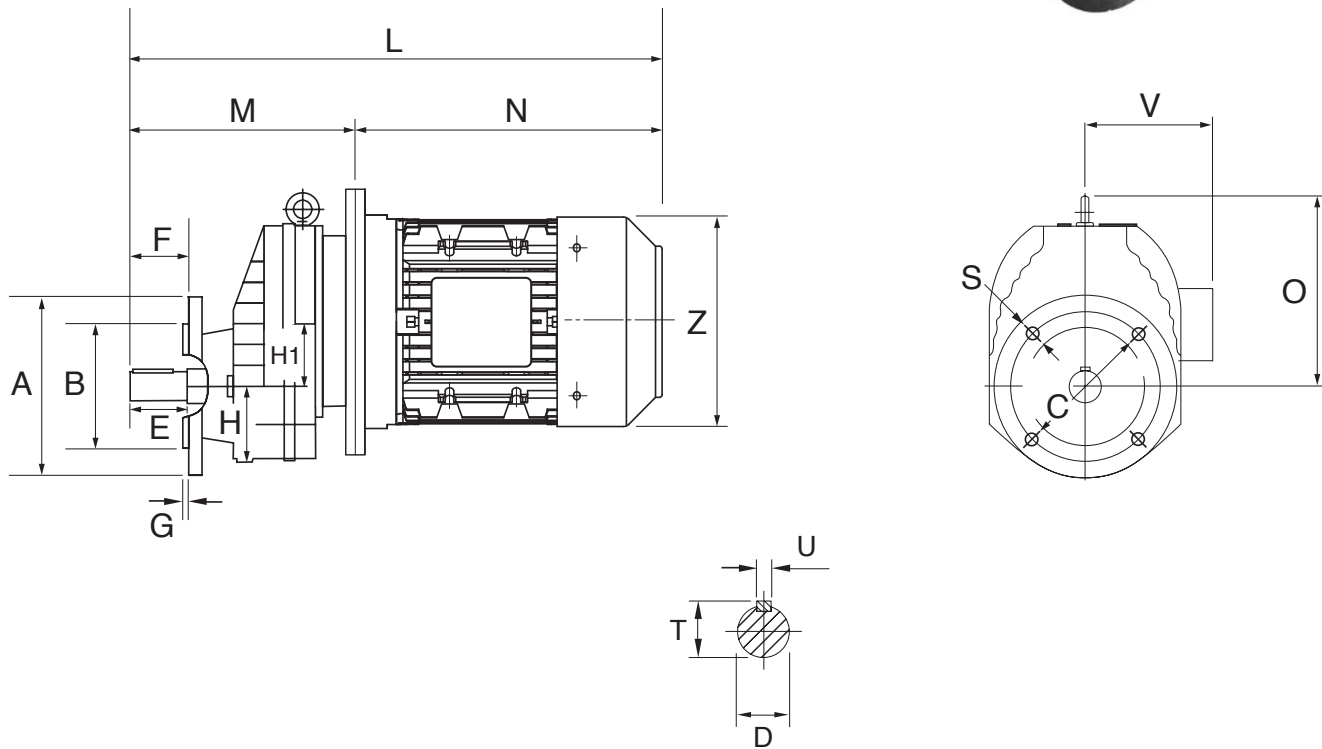

FLANGE MOUNT DIMENSIONAL DATA Sizes are in mm

Size	Frame	A	B	C	D	E	F	G	H	H1	L	M	N	O	S	T	U	V	Z
TJA120	D71 (1)	140	95	115	20 k6	40	40	3	62	52	476	261	215	139	9	22.5	6	114	138
	D80 (1)										527	287	240					134	158
	D90 (1)	160	110	130				3.5			577	287	290		9			143	177
	D100 (1)	200	130	165				3.5			635	318	317		11			160	200
	D112 (2)	200	130	165				3.5			658	318	340		11			171	220
TJA125	D90 (1)	160	110	130	25 k6	50	50	3.5	70	60	604	314	290	147	9	28	8	143	177
	D100 (2)	200	130	165				3.5			662	345	317		11			160	200
	D112 (2)	250	180	215				4			685	345	340		13.5			171	220
	D132 (2)	250	180	215				4			796	378	418		13.5			190	261
TJA130	D90 (1)	200	130	165	30 k6	60	60	3.5	78	72	609	319	290	181	11	33	8	143	177
	D100 (1)										680	363	317					11	160
	D112 (2)	250	180	215				4			703	363	340		13.5			171	220
	D132 (2)	250	180	215				4			841	423	418		13.5			190	261
TJA140	D132 (2)	250	180	215	40 k6	80	80	4	98	93.5	878	460	418	232	13.5	43	12	190	261
	D160 (2)										1057	505	552					13.5	231
	D180 (2)	300	230	265				4			1125	505	620		13.5			260	368
TJA150	D132 (2)	300	230	265	50 k6	100	100	4	118	116	920	502	418	281	13.5	53.5	14	190	261
	D160 (2)										1099	547	552					13.5	231
	D180 (2)	350	250	300				5			1167	547	620		17.5			260	368
	D200 (2)	350	250	300				5			1219	584	635		17.5			260	368
TJA160	D160 (2)	350	250	300	60 m6	120	120	5	135	130	1141	589	552	319	17.5	64	18	231	313
	D180 (2)										1209	589	620					17.5	260
	D200 (1)	450	350	400				5			1261	626	635		17.5			260	368
	D225 (2)	450	350	400				5			1331	661	670		17.5			332	465

Mounting

Before mounting your Techtop geared unit ensure the mounting foundations are flat and solid.

Avoid mounting the geared unit on light fabricated steel frames or brackets which could cause amplifications of operating noise.

Shaft Alignment

Check the gearbox output shaft and the driven shaft to ensure they are properly aligned. Remember, overloads on the bearings and gear housing can be a result of incorrectly aligned shafts.

Tips for connecting the driven load

Fitting of pulleys, sprockets, etc.

The diameter of pulleys, sprockets or pinions should be selected to keep the overhung load on the output shaft within the figure recommended for the particular gearbox.

The centre line of the load pull should ideally be as close as possible to the inside end of the gearbox output shaft.

If you are using a coupling be sure to align both halves. When fitting couplings, sprockets and pinions, etc. to the gearbox output shaft “do not hammer on” as the bearings and circlip locations could be damaged. If the part is too tight try heating before fitting.

Electrical Connections

Due to variances between motor types available and our flexibility of fitting alternative degrees of protection it is important to assess each individual motor when connecting.

A Motor Connection Diagram is supplied in the motor terminal box. Wiring must be capable of withstanding the full load motor current (see motor nameplate) without causing overheating or voltage drop at motor terminals.

Initial Running

Ensure that breather supplied is fitted to its correct position ref. page 15 – 16.

To gain maximum life out of the gearbox it is recommended, if circumstances permit, to run it in under gradually increasing load, reaching full load after approximately 24 hours.

Oil Change

After approximately 200 hours running with a new geared unit it is desirable to drain and refill with clean oil, after which the oil should be drained, flushed and replaced every 5,000 operating hours or every 18 months whichever occurs first. This information relates to I-S-O 320 Viscosity Mineral Oil which is supplied by Techtop as standard unless otherwise specified.

Intervals between oil replacement could vary subject to oil operating temperature. These recommendations are based on sump temperatures up to 80°C, measured at the drain plug. It is important to maintain regular inspections of the oil level, breather efficiency, topping up levels where necessary.

Attention to Oil Seals

The input and output shafts of the gearbox are fitted with contact type oil seals to prevent oil leakage along the rotating shafts. The oil seals should be replaced if the gearbox is overhauled.

Oil Filling

Remove oil filler breather and oil level plugs and pour oil into top oil filler hole until oil commences to flow from oil level hole refer page 15 –16 for details. Seal and replace plugs before operating.

NB: Technical information contained in this manual is subject to continual improvement and could change without warning.

LUBRICATION



All Techtop TJA1 geared units are normally delivered with oil according to mounting position specified by the purchaser. If a mounting position is not specified, geared units will be supplied filled with oil for B3 mounting.

The following lubricants are suitable for use in the Techtop TJA1 units rated at -10 to + 80 degree celcius:

Shell - Omala HD320

BP - Energol HTX320

Mobil - Mobilgear SHC0630

For applications with abnormal ambient temperatures we recommend alternative lubricant be utilized. Ambient operating temperature range for standard 320, grade oil supplied is approx. -10°C to + 40°C.

Techtop should be consulted where operating temperatures exceed this range.

Lubricant fill quantities

The specified fill quantities are recommended values .The precise values vary depending on the number of stages and gear ratio. When filling, it is essential to check the oil level plug since it indicates the precise oil capacity.

The following tables show referenced values for lubricant fill quantities in relation to the Mounting position M1 ~M6

FOOT MOUNT

Gear unit type	Fill quantity(L)					
	M1	M2	M3	M4	M5	M6
TJA120	0.6	0.8	1.3	1.3	0.9	0.9
TJA125	0.8	0.8	1.7	1.9	1.1	1.1
TJA130	1.1	1.5	2.6	2.7	1.6	1.6
TJA140	1.7	2.5	4.8	4.8	2.9	2.9
TJA150	2.1	3.4	7.4	7	4.8	4.8
TJA160	3.9	5.6	11.6	11.9	7.7	7.7

FLANGE MOUNT

Gear unit type	Fill quantity(L)					
	M1	M2	M3	M4	M5	M6
TJA120	0.5	0.8	1.1	1.1	0.7	0.7
TJA125	0.7	0.8	1.5	1.7	1	1
TJA130	0.9	1.5	2.4	2.5	1.6	1.6
TJA140	1.6	2.5	4.9	4.7	2.9	2.9
TJA150	2.1	3.6	7.1	7	4.8	4.8
TJA160	3.1	5.9	11.2	10.5	7.2	7.2

LUBRICATION POINTS

Foot Mounted

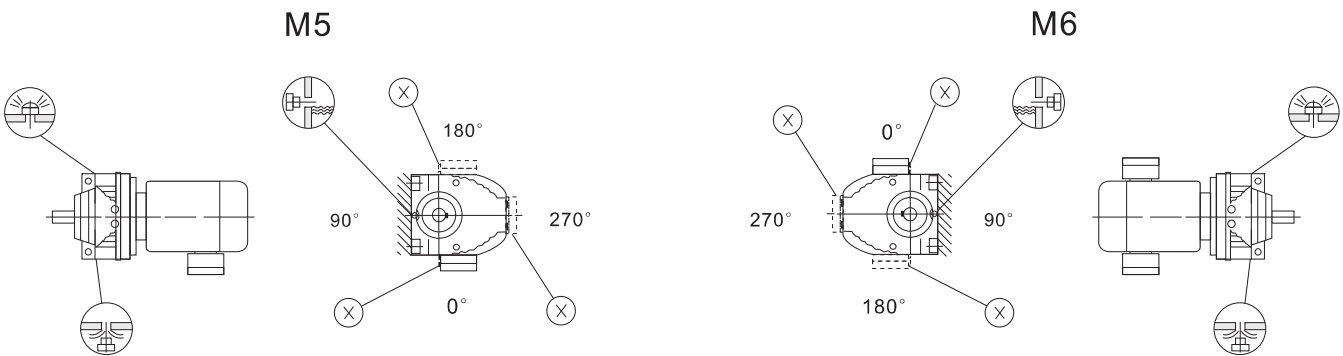
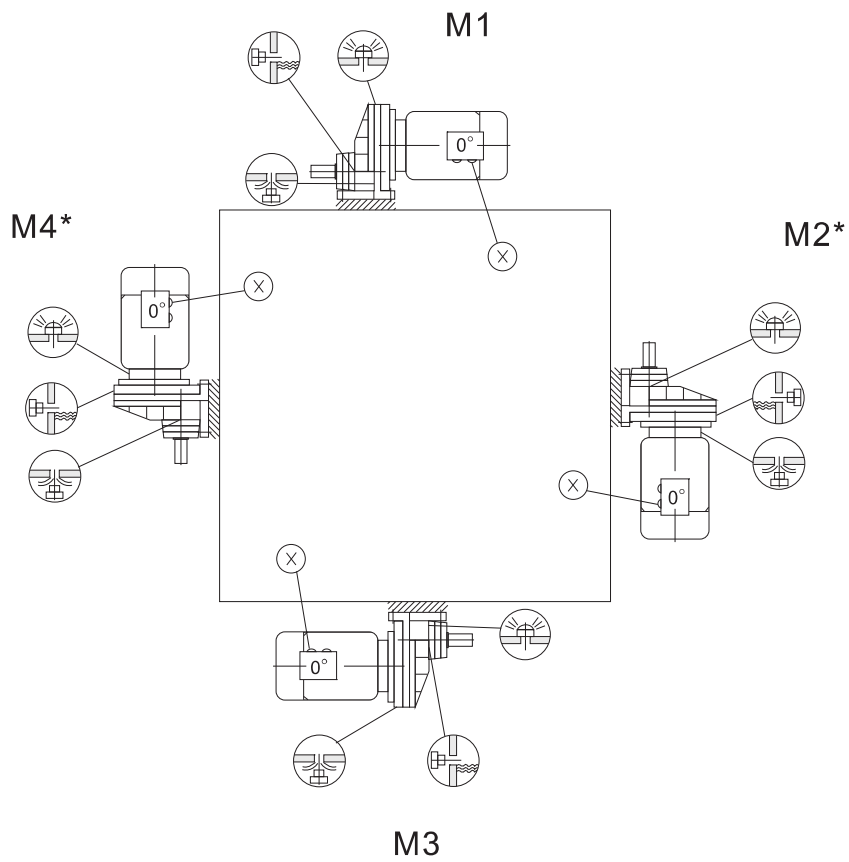
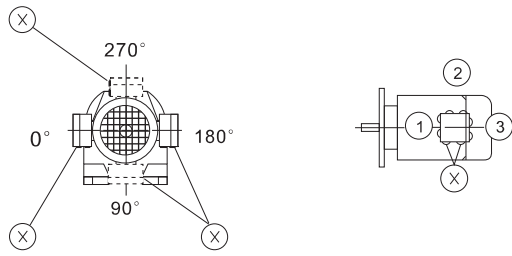
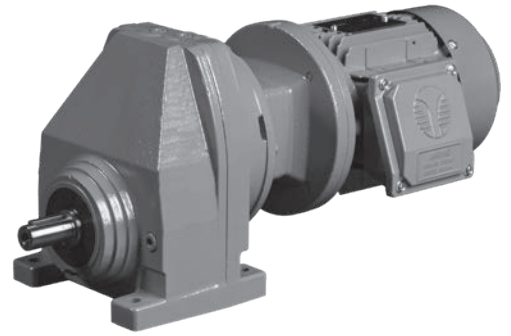

LUBRICATION POINTS

Flange Mounted

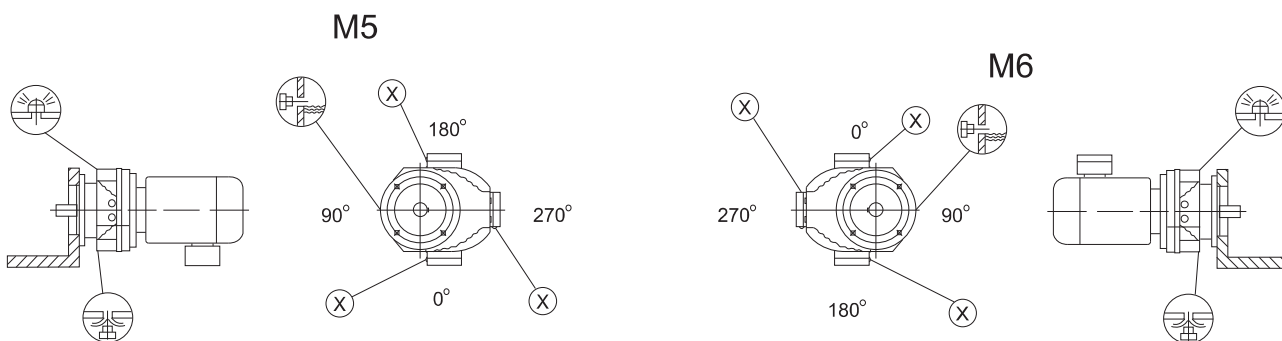
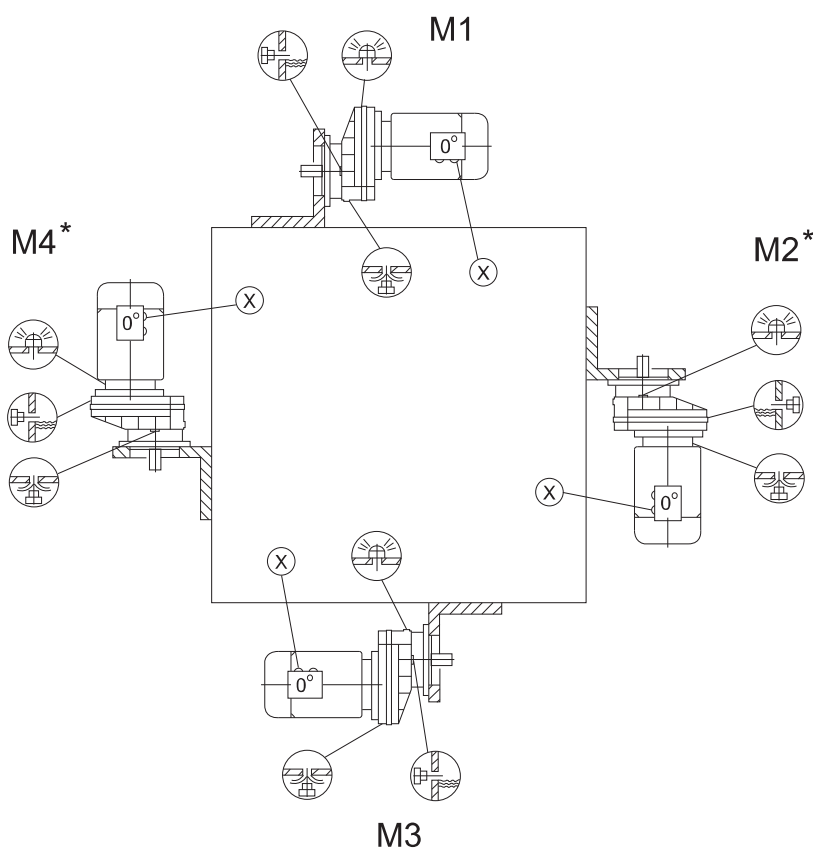
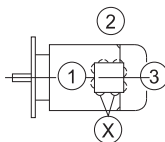
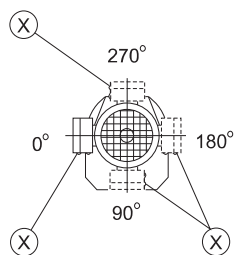



OFFICES

VICTORIA HEAD OFFICE

33-35 Gaine Road
Dandenong Sth VIC 3175
P: +61 (0) 3 9753 2222
F: +61 (0) 3 8692 6670
E: sales@techttop.com.au

QUEENSLAND

3/47 Learoyd Road
Acacia Ridge QLD 4110
P: +61 (0) 7 3106 5111
F: +61 (0) 7 3505 5394
E: qldsales@techttop.com.au

NEW SOUTH WALES

2/7 Kelham Place
Glendenning NSW 2761
P: +61 (0) 2 9114 6955
F: +61 (0) 2 8072 3389
E: nswsales@techttop.com.au

SOUTH AUSTRALIA

Unit 6/1C Oldsmobile Terrace
Dudley Park SA 5008
P: +61 (0) 8 8829 3088
E: sasales@techttop.com.au

WESTERN AUSTRALIA

1 Kalgan Road
Welshpool WA 6106
P: +61 (0) 8 9908 9111
E: wasales@techttop.com.au

AUSTRALIAN DISTRIBUTORS – MGP TAS PTY LTD

47A Elizabeth St
Devonport TAS 7310 Australia
P: +61 (0) 3 6441 5236
F: +61 (0) 3 6441 5237
E: sales@mgptas.com.au

NEW ZEALAND DISTRIBUTORS – JOHN BROOKS LTD

AUCKLAND

5 Andromeda Cres
East Tamaki, Auckland 2013
Freephone: 0800 48 49 50
P: +64 9 274 7114
F: +64 9 274 8497
E: salesakl@johnbrooks.co.nz

WELLINGTON

495 Hutt Road
Lower Hutt, Wellington 5010
Freephone: 0800 24 34 44
P: +64 4 568 6196
F: +64 4 568 6198
E: saleswn@johnbrooks.co.nz

CHRISTCHURCH

120 Wigram Road
Canterbury, Christchurch 8025
Freephone: 0800 37 38 39
P: +64 3 366 9514
F: +64 3 379 4876
E: saleschc@johnbrooks.co.nz