

ISM - BSM

INPUT SOLID SHAFT AND BACK-STOP MODULES

for assembly on gearbox Series:

- RS
- RT
- RD
- RN
- RO
- RV



CONTENTS



Description	2
Modular system	2
Mounting selection.....	3
Freewheels.....	4
Freewheel lifetime	5
Dimensions ISM - BSM.....	6
Dimensions BSM-G	7
Component parts	8

The input modules ISM with solid shaft and BSM with back-stop can be easily fitted on the majority of VARVEL gearboxes, no-flange input version «S», and flexible coupling «G» in few minutes and with a simple screwdriver help only.

ISM - Input shaft module

The input shaft is supported by two sealed grease-packed ball bearings type 2RS and therefore, does not need any lubrication for life. A half-coupling is provided for direct coupling to corresponding VARVEL gearboxes.

BSM - Back-stop module

Manufactured in two versions, solid shaft input with ball bearing and back-stop bearing and IEC or NEMA flange, allows the mounting to any Varvel gearboxes with flexible coupling «G» input.

Information on availability of motor flanges, powers, torques and reduction ratios of the gearbox to which the modules ISM and BSM are fitted to, are shown in relevant catalogues RS-RT, RD and RN-RO-RV.

Input loads of ISM modules are the external input loads that are shown on page 20 of the catalogue RS-RT.

Modular System

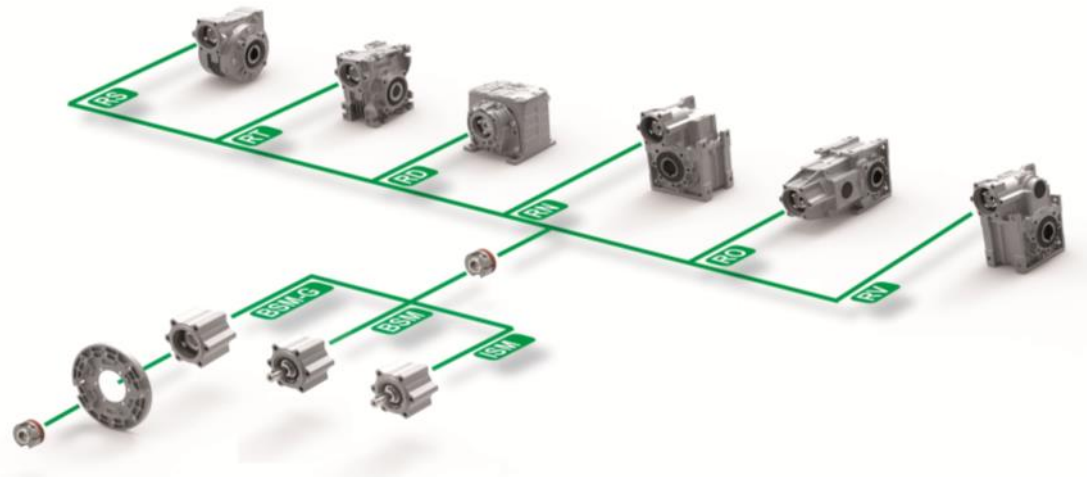



ISM BSM BSM-G	Coupling	RS	RT	RD (2)	RD (3)	RN (2)	RN (3)	RO (2)	RO (3)	RV
40	G3	40	40	02 (*)	03	---	---	---	---	---
50	G5	50	50	12	13	12	13	02	13	13
60	G5	60	60	---	---	---	---	---	---	---
70	G6	70	70	22	23 (§)	22	23	12	23	23
85	G6	85	85	32	33	32	33	22	33	33
110	G6	110	110	42	43	42	43	22	33	33
				---	---	---	---	32	43	43

(2) - two stages
 (3) - three stages
 (*) - RD02 → G5
 (§) - RD23 → G5

Advantages of the built-in clamp-jaw coupling:

- One gearbox only for multiple motor frames of IEC, NEMA, Brushless and DC motors thanks to a unique motor-adapter/coupling kit package
- Greater flexibility
- Increased stock rotation
- Elimination of fretting corrosion between key and keyway
- Gearbox / motor connection with zero backlash
- Allowed angular misalignment 1° max.
- High torsional rigidity
- High vibration damping

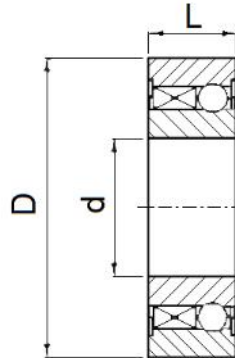

BSM BSM-G	Freewheel	d _{0.01} mm	D _{h5} mm	L mm	rpm _{max}	Load capacity		Torque [Nm]	C [Nm]	Weight [kg]
						A [N]	B [N]			
BSM40	UK 17 2RS	17	40	17	7350	7900	3800	30	0.056	0.09
BSM-G40 BSM50 BSM60	UK 20 2RS	20	47	19	6000	9400	4450	50	0.060	0.15
BSM-G50 BSM70	UK 25 2RS	25	52	20	5200	10700	5450	85	0.060	0.18
BSM-G60 BSM-G70 BSM85 BSM110	UK 30 2RS	30	62	21	4200	11700	6450	138	0.075	0.27
BSM-G85 BSM-G110	UK 35 ZZ	35	72	17	3600	12600	7250	175	0.058	0.30

A - Dynamic load
 B - Static load
 C - Resistant torque (idle)

Max. torque = 2 x nominal torque

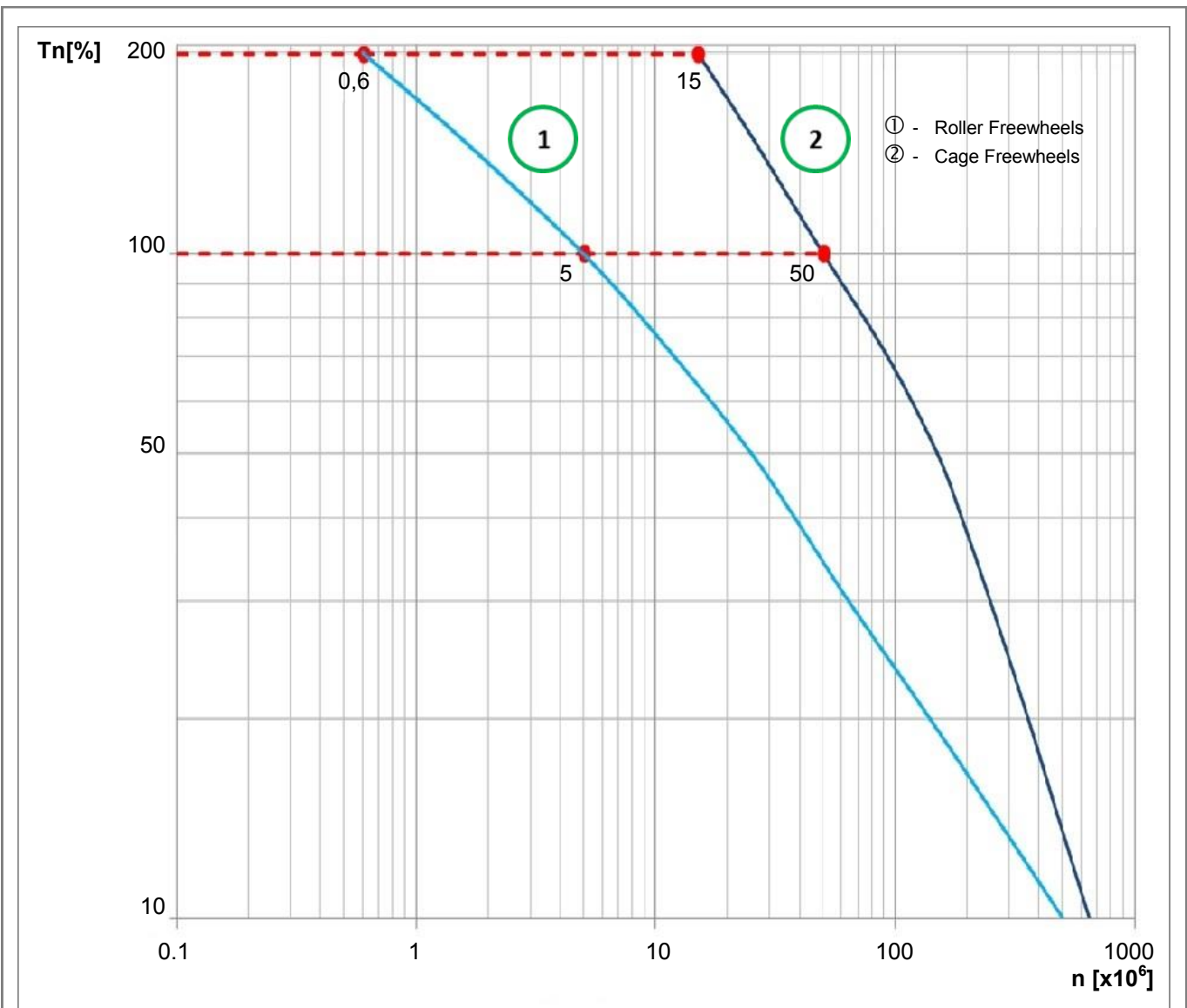

BSM and BSM-G modules are fitted with cage freewheels of the type ② only .
 The curve shows the lifetime of the freewheels according to the application load and possible starting-up number.
 Starting up is meant as the locking action of force feedback of the wheel as regards to idle motion direction.
 Bigger the load T_n [%] lower the possible starting-up n [$\times 10^6$] and working hours.

ISM & BSM

ISM - Input shaft module
BSM - Back-stop module

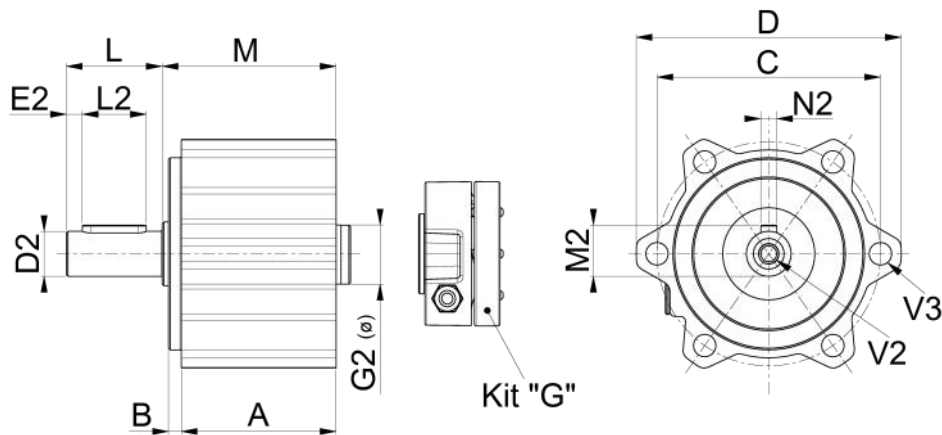

ISM BSM	40	50	60	70	85	110
A	45.5	48.5	48.5	55.5	57	58
B	3.5	4	5	5	5	6
C	61	70	80	85	100	106
D	73	83	94.5	101.5	118.5	125
D2_{h6}	11	14	19	19	24	28
E2	2.5	5	5	5	5	5
G2	14	19	19	24	28	28
L	23	30	40	40	50	60
L2	18	20	30	30	40	50
M	53	54.5	56.75	64.75	62	71.5
M2	12.5	16	21.5	21.5	27	31
N2	4	5	6	6	8	8
V2	M4x10	M6x15	M8x20	M8x20	M8x20	M8x20
V3	6	7	7	9	9	9
Kit "G2"	G3 (Ø14) (*)	G5 (Ø19)	G5 (Ø19)	G6 (Ø24) (§)	G6 (Ø28)	G6 (Ø28)
ISM [kg]	0.45	0.65	0.85	1.1	1.6	2.2
BSM [kg]	0.55	0.80	1.0	1.4	1.8	2.4

(*) - RD02 → G5

(§) - RD23 → G5

Note - Kit "G" coupling not included in ISM-BSM modules; to order separate.

BSM-G

BSM-G - Back-stop module for FM motor adapter

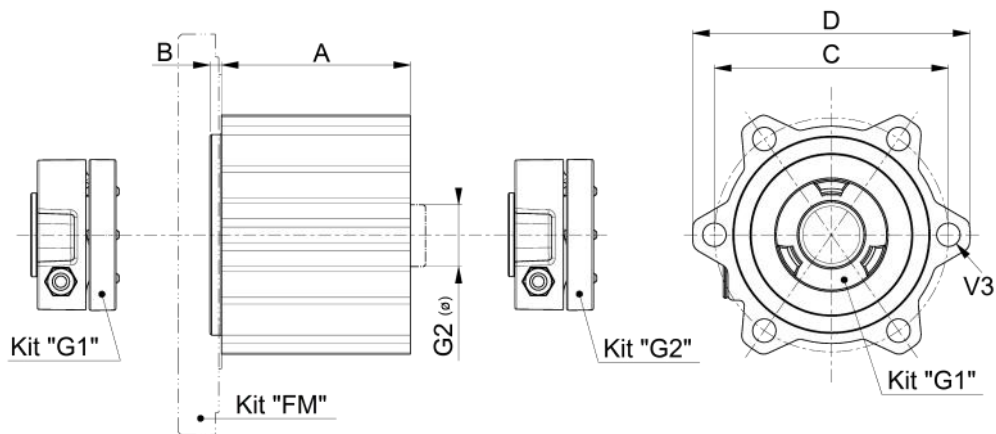

BSM-G	40	50	60	70	85	110
A	50.5	56.5	57	66.5	67	67
B	3.5	3.5	4.75	4.75	5	6
C	61	70	80	85	100	106
D	73	83	94.5	101.5	118.5	125
G2	14	19	24	24	28	28
V3	6	7	7	9	9	9
Kit "G1"	G3	G5	G5	G5	G6	G6
Kit "G2"	G3 (Ø14) (*)	G5 (Ø19)	G5 (Ø24)	G6 (Ø24) (§)	G6 (Ø28)	G6 (Ø28)
Kit "FM"	K531.206.---	K532.206.---	K539.206.---	K533.206.---	K534.206.---	K535.206.---
BSM-G [kg]	0.40	0.50	0.70	1.0	1.2	1.6

G2 - Motor shaft diameter

(*) - RD02 → G5

(§) - RD23 → G5

Note - Kit "G" coupling not included in ISM-BSM modules; to order separate.

ISM & BSM

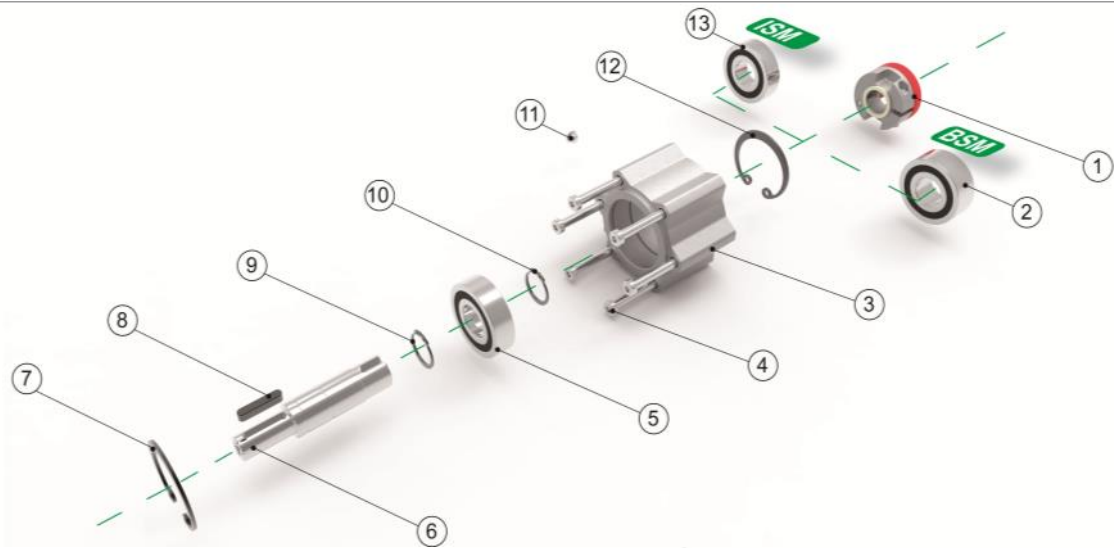

BSM-G

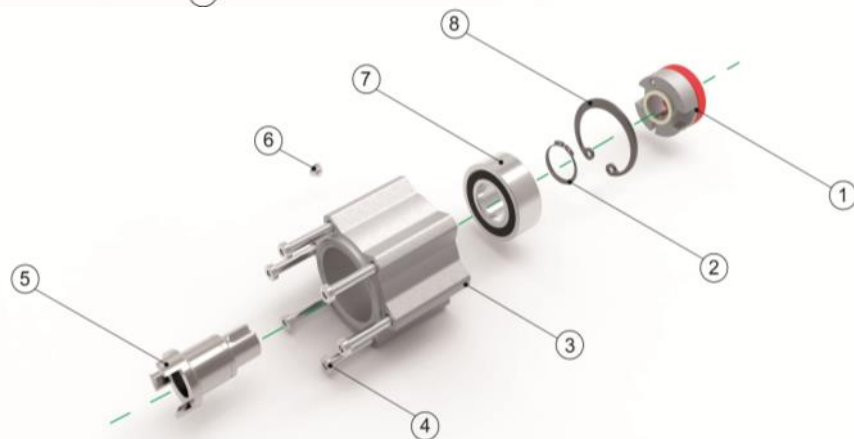

ISM BSM	Description	BSM-G	Description
1	Coupling	1	Coupling
2	Back-stop	2	Seeger ring
3	Body	3	Body
4	Screw	4	Screw
5	Bearing	5	Input shaft
6	Input shaft	6	Plug
7	Seeger ring	7	Back-stop
8	Key	8	Seeger ring
9	Seeger ring		
10	Seeger ring		
11	Plug		
12	Seeger ring		
13	Bearing		