



TECHTOP
AUSTRALIA

Motor Catalogue

Aluminium • Cast Iron • Brake • Flameproof • IE3 & IE4



NEW

MPX

IE4 motor range

Quality. Service. Range.

PHONE 1300 TECH TOP
www.techtop.com.au



The story of Techtop Australia

A business that's powered by people.

Techtop Australia Pty Ltd was established in 2013 through a strategic joint venture with Shanghai Top Motor Co., the largest manufacturer of aluminium electric motors in China. This partnership brought together world-class manufacturing capabilities with deep local market expertise, forming a foundation for excellence in industrial product supply across Australia and New Zealand.

The company is led by Director Rohan Pollard and Chairman Jack Gringlas OAM, whose combined experience in the Australian industrial sector spans over five decades. Their leadership has guided Techtop Australia's growth into a nationally recognised provider of electric motors, transmission products, and variable speed drives—known for quality, reliability, and service.



Headquartered in Dandenong, Victoria, Techtop Australia operates sales offices and warehouses in every mainland state—with locations in Melbourne, Sydney, Brisbane, Adelaide, and Perth, as well as a regional presence in Mackay, Queensland. This national footprint makes us the only company in our sector with direct representation across all major regions, ensuring rapid response times, consistent stock availability, and personalised service.

In 2024, Techtop Australia expanded into New Zealand through the acquisition of John Brooks, a respected and long-established provider of industrial solutions. With offices in Auckland and Christchurch, this acquisition has strengthened our regional presence and enhanced our ability to support customers across Australasia.

Techtop Australia is part of a global organisation, with Techtop partners operating in America, Canada, Europe, and the UAE, allowing us to leverage international innovation and supply chain strength while maintaining a strong local focus.

Each of our offices is led by experienced local managers who are well-regarded within the industry and trusted by our diverse customer base. Our team is made up of professional, knowledgeable, and enthusiastic staff, all committed to delivering outstanding customer service and technical support.



CONTENTS

	Page
EVAPORATIVE COOLER PUMPS	4
ROLLED BODY B56 & BUILDERS RANGE	5
AIR MOVEMENT PSC MOTORS	6
TM SERIES – ALUMINIUM SINGLE PHASE	8
TMY SERIES PERFORMANCE DATA	9
TMY SERIES MOTOR OUTLINE DIMENSIONS	10
TMY SERIES DIMENSIONAL DATA	10
TML SERIES PERFORMANCE DATA	11
TML SERIES MOTOR OUTLINE DIMENSIONS	12
TML SERIES DIMENSIONAL DATA	12
TAI / TAP SERIES – ALUMINIUM THREE PHASE	13
TAI SERIES PERFORMANCE DATA	15
TAP SERIES PERFORMANCE DATA	16
TAI / TAP MOTOR OUTLINE DIMENSIONS	17
TAI / TAP SERIES DIMENSIONAL DATA	17
TAIB SERIES – BRAKE MOTORS	18
TAIB SERIES MOTOR OUTLINE DIMENSIONS	19
TAIB SERIES DIMENSIONAL DATA	19
TCI / TCP SERIES – CAST IRON THREE PHASE	20
TCIM SERIES – MINING SPECIFICATION	23
TCI / TCIM SERIES PERFORMANCE DATA	24
TCP SERIES PERFORMANCE DATA	26
TCI / TCP / TCIM SERIES MOTOR OUTLINE DIMENSIONS	27
TCI / TCP / TCIM SERIES DIMENSIONAL DATA	27
MPX SERIES – IE4 PREMIUM	28
MPX SERIES PERFORMANCE DATA	30 - 31
TCI / TCP / TCIM / MPX SERIES MOUNTING ARRANGEMENTS	32
TCI / TCP / TCIM / MPX SERIES MAXIMUM STARTING TIME	32
TCI / TCP / TCIM / MPX SERIES STARTS PER HOUR	32
TCD YBX3 SERIES – 3 PHASE FLAMEPROOF INDUCTION MOTORS	33
TCD YBX3 SERIES PERFORMANCE DATA	35
TCD YBX3 SERIES DIMENSIONAL DATA & DRAWINGS	39
IP RATING CHART	41
FORCE VENTILATION KITS	42

EVAPORATIVE COOLER / PUMPS

Techtop's evaporative pump is a recirculating pump used in evaporative cooler applications. Its high grade 303 stainless steel shaft provides superior rust resistance, fitted with high quality ball bearings for low noise and smooth running.



Features

- Superior corrosion resistance – 303 grade Stainless Steel shaft
- Direct replacement for all major brands
- Proven long life to withstand Australian conditions
- Auto reset overload protection
- Continuous S1 duty 240V 50Hz
- Optional filter basket available

Model	Output (W)	Current (A)	Water Head Litres Per Minute	600mm	1000mm	1200mm	1400mm	1600mm
WEP19ST	4	0.34	Flow L/min	19	16	14.5	12.5	9.5
WEP28ST	10	0.35	Flow L/min	24	21.5	20	18	16.5
WEP38ST	15	0.45	Flow L/min	29.5	27.5	26	24.5	23
WEP50ST	20	0.5	Flow L/min	38	35.5	34	32	30.5



GENERAL PURPOSE – CSCR

Part no.	Power	Description	Shaft Size
TNA3703A	0.37kW	4 Pole Foot Mount B56	5/8" shaft
TNA3703B	0.56kW	4 Pole Foot Mount B56	5/8" shaft
TNA3703C	0.75kW	4 Pole Foot Mount B56	5/8" shaft
TNA3708A	1.10kW	4 Pole Foot Mount B56	3/4" shaft
TNA3708B	1.50kW	4 Pole Foot Mount B56	3/4" shaft

FAN MOTORS – PSC

Part no.	Power	Description	Shaft Size
TNA3626B1	0.56kW	4 Pole Foot Mount B56	5/8" shaft
TNA3626C1	0.75kW	4 Pole Foot Mount B56	5/8" shaft
TNA3626D1	0.37kW	6 Pole Foot Mount B56	5/8" shaft
TNA3626H (415V)	0.37kW	4 Pole Foot Mount B56	5/8" shaft

AUGER/GRAIN FEEDER MOTORS – CSCR

Part no.	Power	Description	Shaft Size
TNA3910A	0.37kW	4 Pole Oil Burner Flange B56	1/2" shaft
TNA3910B	0.56kW	4 Pole Oil Burner Flange B56	1/2" shaft
TNA3910C	0.75kW	4 Pole Oil Burner Flange B56	1/2" shaft
TNA3910H (415V)	0.72kW	4 Pole Oil Burner Flange B56	1/2" shaft

BUILDERS RANGE – CSCR

Part no.	Power	Description	Shaft Size
TA3766B	1.70kW	2 Pole Foot Mount IEC	3/4" shaft (Bricksaw)
T7021A5/8	0.75kW	4 Pole Foot Mount IEC	5/8" shaft (Cement Mixer)
T7025A	1.65kW	2 Pole B56 Foot IEC frame	19mm shaft (Compressor motor)
T7025B	2.4kW	2 Pole B56 Foot IEC frame	19mm shaft (Compressor motor)

AIR MOVEMENT / PSC MOTORS

Techtop's TKR single shaft series are ideally suited for blowers, ducted heating, evaporative cooling along with many other air movement applications. The motors are designed to meet industry standards and can directly replace other motor brands. Additional models are available upon request and can be designed to suit customer specific requirements.



Features

- Permanent split capacitor
- Vented or enclosed options
- Various mounting designs
- Thermal protection
- Ball bearing
- Single speed, variable speed and multi speed designs are available

SINGLE SHAFT MOTOR SPECIFICATIONS

Model	Output Watts	FLA	RPM High Speed	No. of Speeds	Run Capacitor	Volt / Hz	Rotation	Mount
TKR4A031RSM	315	2.6	1350	3	4 / 440	240 / 50	CW	Resilient Rubber
TKR4A060RSM	600	3.7	1200	3	15 / 440	240 / 50	CW	Resilient Rubber
TKR4A075RSM	750	4.3	1360	3	20 / 440	240 / 50	CW	Resilient Rubber
TKR6A037BSM	370	2.4	890	3	12 / 440	240 / 50	CW	Band
TKR6A037BSSB	375	2.4	890	3	12 / 440	240 / 50	CCW	Band

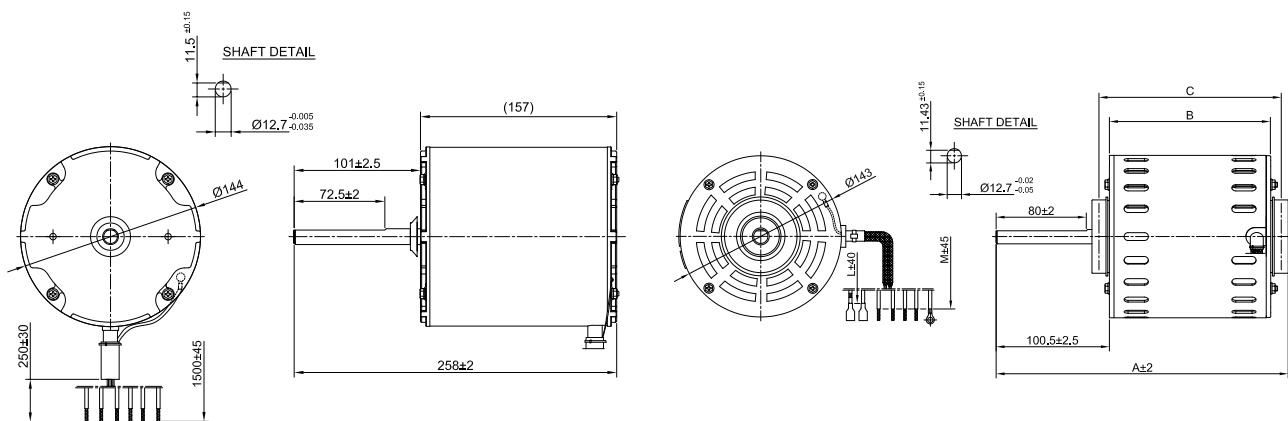

SINGLE SHAFT DIMENSIONAL DATA (mm)

Model	A	B	C	L	M
TKR4A031RSM	236	120	137.5	320	1300
TKR4A060RSM	259	143	161.5	1300	1300
TKR4A075RSM	259	143	161.5	600	2500
TKR6A037BSM	258	157	-	250	1500



DOUBLE SHAFT MOTOR SPECIFICATIONS

Model	Output Watts	FLA	RPM High Speed	No. of Speeds	Run Capacitor	Volt / Hz	Rotation	Mount
TKR4A031CDM	315	2.6	1350	3	4 / 440	240 / 50	CW	Resilient Cradle
TKR4A060CDM	600	3.5	1330	3	15 / 440	240 / 50	CW	Resilient Cradle
TKR4A075CDM	750	4.3	1360	3	20 / 440	240 / 50	CW	Resilient Cradle

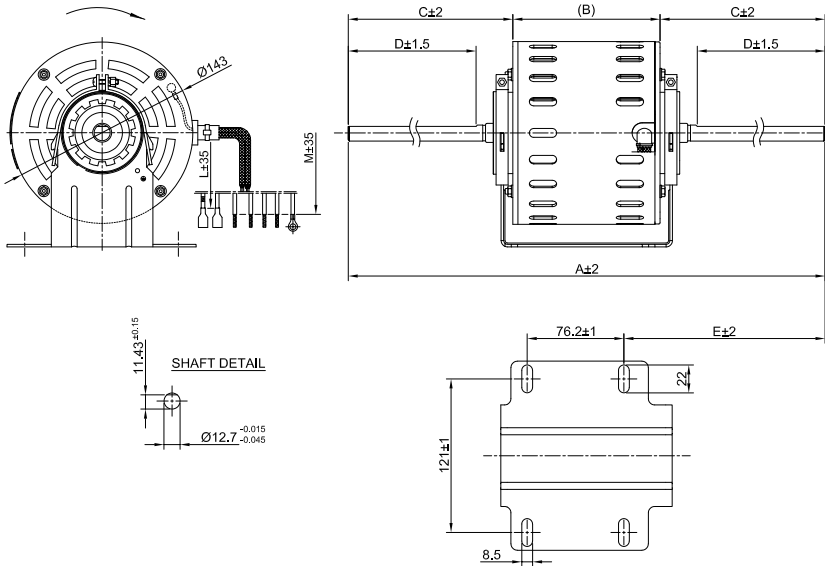

DOUBLE SHAFT DIMENSIONAL DATA (mm)

Model	A	B	C	D	E	L	M
TKR4A031CDM	556	116	220	191	248	1300	1300
TKR4A060CDM	610	140	235	206	268	1000	1000
TKR4A075CDM	610	140	235	206	268	1300	1300

0.06kW to 3.7kW – Sizes 56 to 112

Techtop's TM series are ideally suited to general purpose applications and are available in both permanent split capacitor (TMY) and cap/start-cap/run (TML) series.

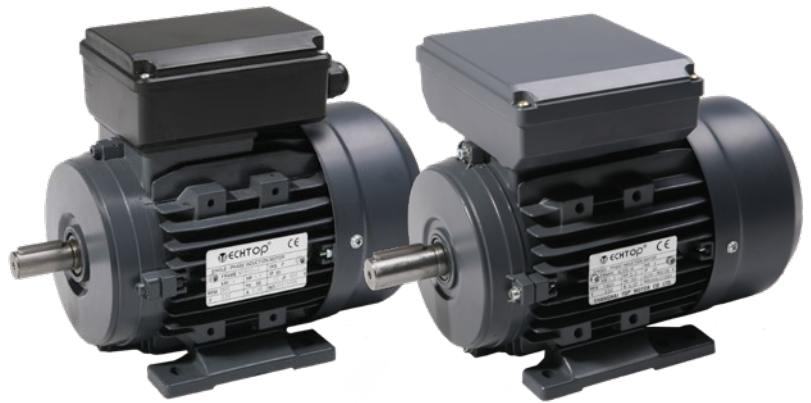

Operating parameters

Standard TM series motors are designed with the following parameters:

- 220V to 240V, 50Hz supply
- Continuous (S1) duty
- Ambient temperatures up to 40°C
- Installation up to 1000 MASL

Standards

Dimensions and rated outputs for the TM series conform to Australian Standard AS/NZS 1359 and International Standards IEC 60034 and IEC 60072.

Insulation class

TM motors are insulated with Class F materials and limited to Class B temperature rise.

IP Protection

The standard degree of enclosure protection is IP 55 (increased IP protection is available). Shafts are fitted with an oil seal as standard.

Thermal Protection

TMY series are fitted with an in-winding auto-reset overload up to 0.75kW.

TML series are fitted with a manual reset overload up to 2.2kW.

Multi-mount design

As standard, TM series motors are fitted with detachable feet. The multi-mount design allows for the motor feet to be removed and repositioned to either side to produce a side mounted terminal box.

Fan & Gearbox application

TM series motors are low weight design and come standard a drilled and tapped hole in the shaft which makes this series ideal for fan applications. This motor series is also ideally suited for fitting to aluminium gearboxes.

Terminal box

The terminal box is manufactured from aluminium and is mounted on top of the motor as standard.

Surface Finish

As standard TM motors are powder coat finish with the final colour being RAL 9005 Jet Black. Other colours are available upon request.

Bearings

Bearings fitted are high quality NSK deep groove ball bearings that are sealed for life.

Frame Size	Bearing Size DE/NDE
56	6201 ZZ
63	6201 ZZ
71	6202 ZZ
80	6204 ZZ
90	6205 ZZ
100	6206 ZZ
112	6206 ZZ

Part Number Logic

Detailed below is the part number logic which should be specified when placing orders. The part number is composed in accordance with the following example:

T	A	4	B	0	1	1	3	TML
1	2	3	4	5-7		8	9-11	

Position 1

T = Techtop

Position 2

A = Aluminium

Position 3

2 = 2 Pole

4 = 4 Pole

6 = 6 Pole

Position 4

A = less than 0.99kW

B = 1.0kW to 9.9kW

Position 5 to 7

Output kW

Position 8

Mounting position

1 = V1

3 = B3

4 = B3/5

5 = B5

6 = B3/B14A

7 = B14A

8 = B14B

9 = B3/B14B

A = B5R

B = B3/B5R

Position 9 to 11

TML = CS/CR series

TMY = PSC series



TMY SERIES PERFORMANCE DATA

Output kW	Full Load Speed [RPM]	Frame Size	Shaft Dia [mm]	Current @ 240v		Efficiency	Power Factor	Torque			Capacitor	Weight Foot Mount [Kg]
				Full Load [A]	Locked Rotor [%]	Full Load [%]	Full Load [%]	Full Load [Nm]	Locked Rotor [% FLT]	Break Down [% FLT]	Run Capacitor [mfd/volt]	
0.09	2760	56A	9	0.76	380	54.0	0.94	0.3	0.65	160	4/450	2.9
0.12	2770	56B	9	0.94	410	58.0	0.92	0.4	0.65	160	6/450	3.2
0.18	2780	63A	11	1.3	380	62.0	0.95	0.6	0.60	170	10/450	4.0
0.25	2780	63B	11	1.7	400	65.0	0.95	0.9	0.60	170	12/450	4.5
0.37	2800	71A	14	2.4	400	67.0	0.95	1.3	0.60	170	16/450	5.1
0.55	2810	71B	14	3.3	430	70.0	0.98	1.9	0.55	170	24/450	7.2
0.75	2810	80A	19	4.4	430	72.0	0.98	2.5	0.35	170	25/450	9.6
1.1	2820	80B	19	6.2	430	75.0	0.98	3.7	0.33	170	35/450	11.0
1.5	2820	90S	24	8.1	460	76.0	0.98	5.1	0.30	180	45/450	14.0
2.2	2820	90L	24	12.2	470	77.0	0.98	7.5	0.30	180	60/450	16.5
3	2860	100L	28	16.0	435	79.0	0.99	10.0	0.35	180	80/450	23.1
0.06	1360	56A	9	0.57	420	48.0	0.92	0.4	0.75	160	4/450	3.5
0.09	1370	56B	9	0.80	360	51.0	0.92	0.6	0.75	160	6/450	3.8
0.12	1380	63A	11	0.99	340	55.0	0.92	0.8	0.65	160	8/450	4.0
0.18	1390	63B	11	1.4	370	57.0	0.92	1.2	0.65	150	10/450	4.6
0.25	1400	71A	14	1.8	420	61.0	0.94	1.7	0.50	150	14/450	5.7
0.37	1400	71B	14	2.4	360	62.0	0.94	2.5	0.50	150	16/450	6.7
0.55	1400	80A	19	3.8	380	64.0	0.95	3.8	0.35	170	20/450	8.2
0.75	1410	80B	19	4.8	400	68.0	0.95	5.1	0.33	170	25/450	9.0
1.1	1410	90S	24	6.6	440	71.0	0.98	7.5	0.33	180	40/450	14.5
1.5	1420	90L	24	8.7	440	73.0	0.98	10.1	0.33	180	45/450	16.2
2.2	1450	100LA	28	12.5	496	79.0	0.93	14.5	0.31	180	70/450	23.4
3	1450	100LB	28	16.1	542	81.0	0.96	19.8	0.31	180	90/450	28.7
0.09	900	63A	11	0.87	200	44.5	0.97	0.96	0.38	153	8/450	5.1
0.12	875	63B	11	1.07	200	47.5	0.98	1.31	0.25	123	11/450	6.0
0.18	920	71A	14	1.39	220	55.5	0.97	1.87	0.50	150	11/450	6.3
0.25	930	71B	14	1.90	250	56.0	0.98	2.57	0.45	150	16/450	7.6
0.37	960	80A	19	2.44	350	66.0	0.96	3.68	0.35	160	20/450	9.0
0.55	955	80B	19	3.35	350	70.5	0.97	5.50	0.35	160	25/450	11.6
0.75	905	90S	24	4.77	260	67.0	0.98	7.91	0.35	160	35/450	13.5
1.1	940	90L	24	6.32	300	74.0	0.98	11.2	0.35	150	50/450	16.2

TMY SERIES MOTOR OUTLINE DIMENSIONS

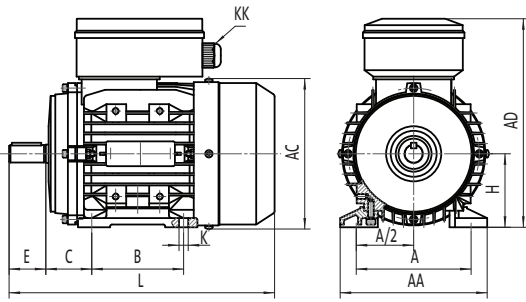

B3

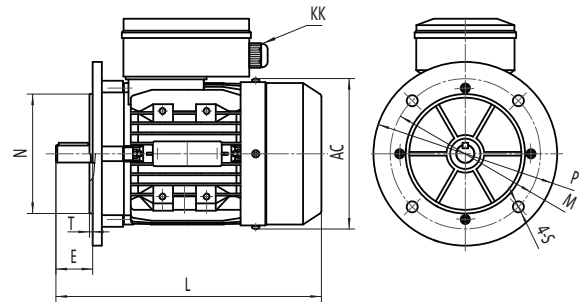

B5

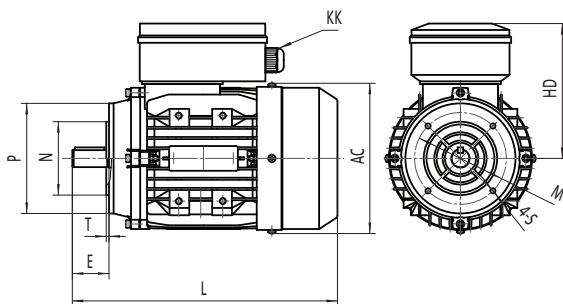

B14

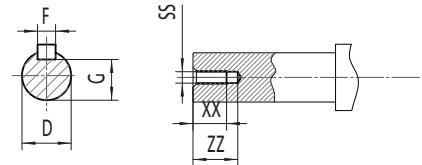

SHAFT

TMY SERIES DIMENSIONAL DATA Sizes are in mm

FRAME	Foot Mounting				Shaft								General				
	H	A	B	C	D	E	F	G	K	SS	XX	ZZ	AA	AD	HD	AC	L
TMY 56	56	90	71	36	9	20	3	7.2	5.8	M3	9	12	110	144	88	117	196
TMY 63	63	100	80	40	11	23	4	8.5	7	M4	10	14	120	181	118	130	220
TMY 71	71	112	90	45	14	30	5	11	7	M5	12	17	132	196	125	147	241
TMY 80	80	125	100	50	19	40	6	15.5	10	M6	16	21	160	226	146	163	290
TMY 90S	90	140	100	56	24	50	8	20	10	M8	19	25	175	243	153	183	312
TMY 90L	90	140	125	56	24	50	8	20	10	M8	19	25	175	243	153	183	337
TMY 100L	100	160	140	63	28	60	8	24	12	M10	22	30	198	265	165	205	369

FRAME	KK	B5					B14A					B14B				
		N	M	P	S	T	N	M	P	S	T	N	M	P	T	S
TMY 56	1-M16*1.5	80	100	120	4-7	3	50	65	80	M5	2.5					
TMY 63	1-M20*1.5	95	115	140	4-10	3	60	75	90	M5	2.5					
TMY 71	1-M20*1.5	110	130	160	4-10	3.5	70	85	105	M6	2.5	95	115	140	3	M8
TMY 80	1-M20*1.5	130	165	200	4-12	3.5	80	100	120	M6	3	110	130	160	3.5	M8
TMY 90	1-M20*1.5	130	165	200	4-12	3.5	95	115	140	M8	3	110	130	160	3.5	M8
TMY 100	1-M20*1.5	180	215	250	4-15	4	110	130	160	M8	3.5	130	165	200	3.5	M10



TML SERIES PERFORMANCE DATA

Output kW	Full Load Speed [RPM]	Frame Size	Shaft Dia [mm]	Current @ 240v		Efficiency Full Load [%]	Power Factor Full Load [%]	Torque			Capacitor		Weight Foot Mount [Kg]
				Full Load [A]	Locked Rotor [%]			Full Load [Nm]	Locked Rotor [% FLT]	Break Down [% FLT]	Start Capacitor [mfd/volt]	Run Capacitor [mfd/volt]	
0.18	2820	63A	11	1.3	514	62.0	0.93	0.61	190	180	30/250	8/450	3.9
0.25	2800	63B	11	1.6	468	67.5	0.94	0.85	230	180	30/250	10/450	4.4
0.37	2780	71A	14	2.3	620	70.0	0.95	1.3	250	170	75/250	12/450	5.3
0.55	2790	71B	14	3.3	580	73.0	0.95	1.9	250	170	100/250	16/450	7.4
0.75	2800	80A	19	4.4	660	74.0	0.97	2.6	250	170	100/250	20/450	9.5
1.1	2810	80B	19	6.2	620	76.0	0.97	3.7	250	170	150/250	30/450	11.2
1.5	2810	90S	24	8.3	640	78.0	0.97	5.1	250	180	200/300	40/450	14.0
2.2	2810	90L	24	12	600	79.0	0.97	7.5	220	180	250/300	50/450	17.0
3	2830	100L	28	15.9	570	80.0	0.98	10.1	220	200	350/300	60/450	25.0
3.7	2900	112M	28	19.1	779	82.5	0.98	12.2	250	180	400/300	60/450	31.0
0.12	1380	63A	11	1.0	594	54.5	0.95	0.83	250	165	30/250	8/450	4.1
0.18	1320	63B	11	1.4	470	55.0	0.99	1.3	250	150	40/250	12/450	4.9
0.25	1380	71A	14	1.9	520	61.0	0.92	1.7	250	160	50/250	12/450	5.9
0.37	1380	71B	14	2.7	540	63.0	0.92	2.6	250	150	75/250	16/450	6.9
0.55	1400	80A	19	3.6	530	67.0	0.94	3.8	250	170	100/250	20/450	9.6
0.75	1410	80B	19	4.5	630	73.0	0.94	5.1	250	170	120/250	25/450	10.8
1.1	1410	90S	24	6.5	590	75.0	0.95	7.5	220	180	150/300	35/450	13.5
1.5	1420	90L	24	8.7	610	76.0	0.95	10.1	220	180	200/300	40/450	16.5
2.2	1430	100LA	28	12.1	600	78.0	0.97	14.7	220	180	350/300	50/450	24.0
3	1440	100LB	28	16.3	560	79.0	0.97	19.9	220	180	450/300	60/450	30.0
3.7	1440	112M	28	19.8	580	80.0	0.97	24.5	200	200	600/300	60/450	36.0
0.18	930	71A	14	1.30	520	60.0	0.97	1.85	230	172	30/250	10/450	6.2
0.25	940	71B	14	1.85	470	58	0.97	2.54	230	180	40/250	14/450	6.8
0.37	935	80A	19	2.38	520	67.0	0.97	3.78	220	155	50/250	16/450	10.1
0.55	935	80B	19	3.33	540	71.0	0.97	5.62	220	145	75/250	20/450	10.8
0.75	945	90S	24	4.55	680	71.0	0.97	7.58	210	145	150/250	30/450	13.7
1.1	945	90L	24	6.45	680	74.0	0.96	11.1	250	145	200/300	45/450	17.3
1.5	960	100LA	28	8.37	700	77.0	0.97	14.9	230	155	200/300	45/450	23.8
2.2	965	112M	28	11.5	830	82.0	0.97	21.8	250	170	300/300	60/450	31.2

TML SERIES MOTOR OUTLINE DIMENSIONS

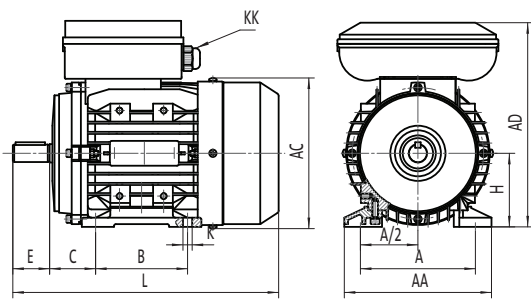

B3

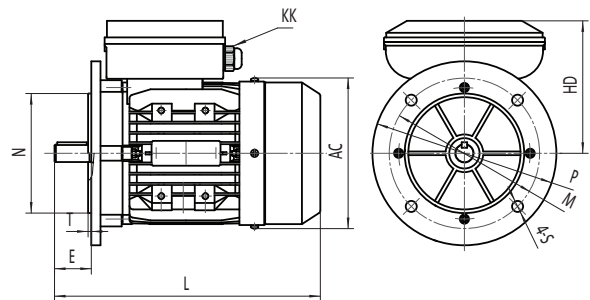

B5

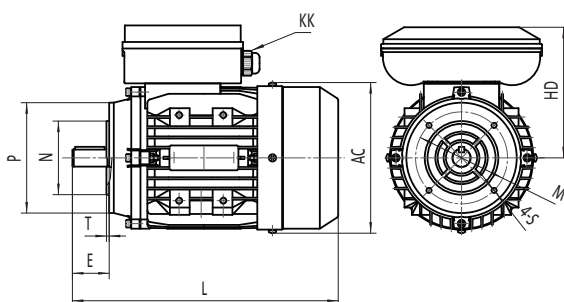

B14

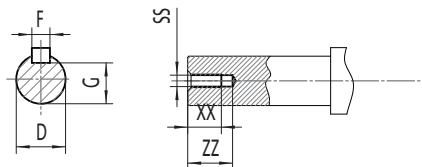

SHAFT

TML SERIES DIMENSIONAL DATA

FRAME	Foot Mounting				Shaft								General				
	H	A	B	C	D	E	F	G	K	SS	XX	ZZ	AA	AD	HD	AC	L
TML 63	63	100	80	40	11	23	4	8.5	7	M4	10	14	120	179	116	130	215
TML 71	71	112	90	45	14	30	5	11	7	M5	12	17	132	194	123	147	255
TML 80	80	125	100	50	19	40	6	15.5	10	M6	16	21	160	223	143	163	290
TML 90S	90	140	100	56	24	50	8	20	10	M8	19	25	175	240	150	183	335
TML 90L	90	140	125	56	24	50	8	20	10	M8	19	25	175	240	150	183	365
TML 100L	100	160	140	63	28	60	8	24	12	M10	22	30	198	271	171	205	405
TML 112M	112	190	140	70	28	60	8	24	12	M10	22	30	220	297	185	229	435

FRAME	KK	B5					B14A					B14B					
		N	M	P	S	T	N	M	P	S	T	N	M	P	T	S	
TML 63	1-M20*1.5	95	115	140	4-10	3	60	75	90	M5	2.5						
TML 71	1-M20*1.5	110	130	160	4-10	3.5	70	85	105	M6	2.5	95	115	140	3	M8	
TML 80	1-M20*1.5	130	165	200	4-12	3.5	80	100	120	M6	3	110	130	160	3.5	M8	
TML 90	1-M20*1.5	130	165	200	4-12	3.5	95	115	140	M8	3	110	130	160	3.5	M8	
TML 100	1-M20*1.5	180	215	250	4-15	4	110	130	160	M8	3.5	130	165	200	3.5	M10	
TML 112	1-M25*1.5	180	215	250	4-15	4	110	130	160	M8	3.5	130	165	200	3.5	M10	



0.06kW to 37kW – Frame 56 to 200L

Techtop's TAI/TAP aluminium series motors are suitable for all industrial applications where optimal design performance and low weight are key factors.



Operating parameters

Standard TAI/TAP series motors are designed with the following parameters:

- ☛ 380V to 415V, 50Hz & 440V to 480V, 60Hz supply
- ☛ Continuous (S1) duty
- ☛ Ambient temperatures up to 40°C
- ☛ Installation up to 1000 MASL

Connection

- ☛ 230V Delta / 400V Star (3kW & below)
- ☛ 400V Delta / 690V Star (4kW & above)

Standards

Dimensions and rated outputs for the TAI/TAP series conform to Australian Standard AS/NZS 1359 and International Standards IEC 60034 and IEC 60072.

Standard & High Efficiency

The TAI range complies with MEPS2 requirements of AS/NZS 1359.5:2004 Table A2 (**Standard Efficiency**). The TAP range complies with MEPS2 requirements of AS/NZS 1359.5:2004 Table A3 (**High Efficiency**). Motors are tested in accordance with Test Method A of AS/NZS 1359.102.3 as per IEC 60034-2-1.

Insulation class

TAI/TAP motors are insulated with Class F materials and limited to Class B temperature rise. The windings are spike resistant making them suitable for use with VVVF drives.

Thermistors

As standard all TAI/TAP series motors from 160 frame and above are fitted with one set of PTC thermistors. The thermistor termination is located in the main terminal box and has a trip temperature of 150°C as standard.

Additional 130°C thermistors can be fitted as an option for alarm connection. Thermistors are available as an option for smaller frame sizes.

IP Protection

The standard degree of enclosure protection for TAI series is IP 55 (increased IP protection is available). Shafts are fitted with an oil seal as standard on flange mount and a V ring seal on foot mount.

TAP series are IP66 as standard and are fitted with oil seals on both ends.

Multi-mount design

As standard, TAI/TAP series motors are fitted with detachable feet. The multi-mount design allows for the motor feet to be removed and repositioned to either side to produce a side mounted terminal box.

Alternatively the feet can be removed and the motor mounted from any of the 16 mounting pads.

Fan & Gearbox application

TAI/TAP series motors are low weight design and come standard a drilled and tapped hole in the shaft which makes this series ideal for fan applications. This motor series is also ideally suited for fitting to aluminium gearboxes. *Optional B5R flange is available for gearbox fitment – B5R flanges are one frame size smaller than standard B5 flanges.

Terminal box

The terminal box is manufactured from aluminium and is mounted on top of the motor as standard. Terminal box is separate to the motor body and can be rotated in 90° increments..

Surface Finish

As standard TAI/TAP motors are powder coat finish with final colour being RAL 9005 Jet Black. Other colours are available upon request.

Bearings

Bearings fitted are high quality NSK (or equivalent) deep groove ball bearings that are sealed for life. Bearings are C3 with ZZ seals as standard.

Frame size	Bearing	
	Aluminium	N.D.E
56	6201 ZZ	
63	6201 ZZ	
71	6202 ZZ	
80	6204 ZZ	
90	6205 ZZ	
100	6206 ZZ	
112	6306 ZZ	6206 ZZ
132	6308 ZZ	6208 ZZ
160	6309 ZZ	6209 ZZ
180	6311 ZZ	6211 ZZ
200	6312 ZZ	6212 ZZ

Conduit Entries

Frame Size	Entry Size	Number of Entries
56	M20 x 1.5	1
63	M20 x 1.5	1
71	M20 x 1.5	1
80	M25 x 1.5	2
90	M25 x 1.5	2
100	M20 x 1.5	2
112	M25 x 1.5	2
132	M25 x 1.5	2
160	M32 x 1.5	2
180	M32 x 1.5	2
200	M50 x 1.5	2

Part Number Logic

Detailed below is the part number logic which should be specified when placing orders. The part number is composed in accordance with the following example:

T	A	4	B	0	2	2	5	TAI	B
1	2	3	4	5 - 7		8	9 - 12	13 - 15	

Position 1

T = Techttop

Position 2

A = Aluminium

C = Cast Iron

Position 3

2 = 2 Pole

4 = 4 Pole

6 = 6 Pole

8 = 8 Pole

Position 4

A = less than 0.99kW

B = 1.0kW to 9.9kW

C = 10.0kW to 99.9kW

Position 5 to 7

Output kW

Position 8

Mounting position

1 = V1

3 = B3

4 = B3/5

5 = B5

6 = B3/B14A

7 = B14A

8 = B3/B14B

9 = B14B

A = B5R

B = B3/B5R

Position 9 to 12

TAI = Aluminium Std Eff.

TAP = Aluminium Hi-Eff.

Position 13 to 15

BHR = Brake motor

with hand release

H = Class H insulation



TAI SERIES PERFORMANCE DATA

Output kW	Full Load Speed [RPM]	Frame Size	Shaft Diam. [mm]	Current @400v		Efficiency		Power Factor		Torque				Noise Level dB (A)	Weight Foot Mount [Kg]
				Full Load [A]	Locked Rotor [%]	Full Load [%]	3/4 Load [%]	Full Load [%]	3/4 Load [%]	Full Load [Nm]	Locked Rotor [% FLT]	Pull Up [% FLT]	Break Down [% FLT]		
0.06	1370	56A	9	0.30	314	50.9	46.6	0.56	0.48	0.42	320	302	319	56	2.9
	2715	56A	9	0.32	329	53.5	49.6	0.76	0.65	0.32	228	212	239	58	2.6
	1375	56B	9	0.41	315	52.6	48.7	0.60	0.51	0.62	285	259	280	56	3.2
	840	63A	11	0.43	250	46.3	44.1	0.65	0.55	1.01	213	197	208	54	4.2
0.09	665	71A	14	0.53	233	43.1	38.7	0.57	0.50	1.29	241	235	257	52	5.6
	2700	56B	9	0.36	378	61.6	60.6	0.79	0.68	0.43	249	213	234	58	3.0
	1300	63A	11	0.51	292	54.6	52.1	0.62	0.52	0.88	302	272	279	55	3.7
	830	63B	11	0.56	237	48.0	46.5	0.65	0.55	1.38	219	190	205	54	4.5
0.12	650	71B	14	0.62	259	47.7	44.5	0.59	0.50	1.75	252	247	262	52	6.0
	2710	63A	11	0.55	375	60.7	58.6	0.78	0.66	0.63	244	207	236	58	4.0
	1275	63B	11	0.67	288	56.8	57.3	0.68	0.57	1.35	234	217	228	56	3.7
	880	71A	14	0.66	291	57.8	56.4	0.68	0.57	1.95	227	209	224	55	5.6
0.18	690	80A	19	0.82	291	55.0	51.4	0.58	0.49	2.48	223	202	248	53	8.3
	2715	63B	11	0.71	394	65.6	64.4	0.78	0.67	0.88	271	196	232	60	4.2
	1365	71A	14	0.75	388	63.0	61.7	0.76	0.68	1.74	205	184	224	58	5.0
	850	71B	14	0.84	293	59.7	61.2	0.72	0.61	2.79	195	187	205	56	6.0
0.25	680	80B	19	1.05	307	58.7	55.6	0.58	0.49	3.46	230	207	248	54	9.3
	2770	71A	14	1.04	503	62.8	60.5	0.82	0.73	1.28	288	188	257	61	5.2
	1370	71B	14	1.03	428	67.2	66.3	0.77	0.66	2.60	229	190	228	60	5.8
	900	80A	19	1.32	318	61.2	58.8	0.66	0.55	3.89	197	189	227	56	7.8
0.37	700	90S	24	1.41	309	64.4	61.5	0.59	0.50	4.98	195	176	225	53	11.4
	2800	71B	14	1.41	504	71.3	69.9	0.79	0.69	1.88	302	181	269	61	6.0
	1380	71C	14	1.47	424	66.0	66.5	0.70	0.64	3.84	231	191	218	57	7.1
	1410	80A	19	1.63	449	71.5	70.1	0.68	0.58	3.72	233	190	259	59	8.3
0.55	900	80B	19	1.85	346	65.8	64.4	0.65	0.54	5.79	217	198	234	58	9.1
	700	90L	24	2.1	338	65.3	62.9	0.58	0.49	7.46	195	179	235	57	13.9
	2880	80A	19	1.76	687	80.1	80.2	0.79	0.71	2.5	292	196	302	64	9.5
	1420	80B	19	1.94	550	81.1	81.5	0.69	0.60	5.0	303	270	310	60	10.5
0.75	930	80C	19	2.21	448	76.3	75.9	0.64	0.54	7.7	311	271	296	59	12.3
	940	90S	24	2.22	444	76.3	75.7	0.65	0.54	7.6	225	196	252	58	13.0
	690	100LA	28	2.21	363	72.3	73.3	0.68	0.58	10.4	177	175	213	55	21.0
	2880	80B	19	2.39	758	81.2	81.3	0.82	0.74	3.6	283	186	285	64	10.4
1.1	1430	80C	19	2.73	637	82.3	82.6	0.71	0.62	7.3	309	263	321	61	12.3
	1420	90S	24	2.57	618	82.8	83.8	0.75	0.67	7.4	296	247	297	60	14.3
	950	90L	24	2.98	487	78.4	78.7	0.69	0.60	11.0	207	180	245	59	16.0
	690	100LA	28	3.17	390	74.8	75.2	0.67	0.57	15.1	198	192	230	55	25.0
1.5	2880	90S	24	3.19	690	83.1	83.5	0.83	0.75	5.0	276	187	308	68	13.5
	1440	90L	24	3.35	713	85.5	86.1	0.76	0.68	9.9	316	240	313	60	18.0
	945	100LA	28	3.71	472	80.1	82	0.74	0.66	15.1	172	161	225	59	20.0
	700	112M	28	4.18	403	78.4	79.3	0.68	0.59	20.4	182	180	212	55	25.4
2.2	2890	90L	24	4.61	811	84.0	84.4	0.83	0.75	7.2	300	222	318	68	16.2
	1430	90LB	24	5.02	769	84.3	85.3	0.76	0.66	14.7	426	342	403	60	18.8
	1440	100LA	28	4.55	726	85.8	86.6	0.82	0.76	14.6	260	218	305	62	23.4
	950	112M	28	5.36	547	82.8	83.9	0.73	0.64	22.0	220	181	271	59	26.3
3	710	132S	38	5.95	420	80.0	80.6	0.67	0.58	29.4	186	174	233	55	44.0
	2900	100L	28	5.59	920	87.0	87.6	0.90	0.87	9.9	309	249	351	78	22.3
	1445	100LB	28	6.27	760	86.0	86.6	0.80	0.73	19.8	239	244	325	62	26.3
	960	132S	38	6.42	601	85.5	86.6	0.76	0.70	29.6	188	157	258	58	43.0
4	715	132M	38	7.8	529	82.7	83.1	0.70	0.61	39.9	231	203	274	58	51.0
	2915	112M	28	7.56	960	87.4	87.7	0.89	0.84	13.1	332	208	365	78	28.7
	1440	112M	28	8.17	781	87.5	88.2	0.82	0.75	26.4	257	231	335	73	35.2
	960	132MA	38	9.21	583	84.7	85.6	0.74	0.68	39.6	200	165	257	58	52.0
5.5	710	160MA	42	9.90	477	83.5	84.5	0.70	0.61	53.5	189	172	240	58	60.0
	2920	112MB	28	10.3	1014	88.6	88.9	0.87	0.82	18.0	349	281	411	71	30.0
	2910	132SA	38	10.3	823	87.8	88.3	0.89	0.85	18.0	244	195	343	69	45.4
	1435	112MB	28	11.3	829	87.9	88.8	0.80	0.73	36.6	378	319	359	66	37.0
	1460	132S	38	11.0	856	88.1	88.5	0.83	0.77	35.9	217	193	350	63	49.4
	960	132MB	38	12.4	654	86.3	87.5	0.75	0.69	54.5	240	184	261	58	58.5
7.5	715	160MB	42	13.3	505	85.1	86.1	0.70	0.62	73	209	185	263	64	82.0
	2920	132SB	38	13.9	1029	89.2	89.6	0.89	0.86	24.5	314	202	366	69	50.0
	1450	132M	38	14.3	823	89.5	90.4	0.85	0.82	49.4	299	117	295	63	62.3
	960	160M	42	16.0	688	87.7	88.7	0.77	0.70	74.1	257	187	288	61	74.0
9.2	710	160L	42	17.6	596	86.5	87.4	0.71	0.63	99.9	271	158	295	64	92.0
	2920	132MB	38	16.4	944	89.1	90.1	0.91	0.89	30.2	252	189	331	69	52.4
	1455	132MB	38	17.4	870	89.5	90.4	0.85	0.81	49.4	295	171	312	63	60.1

TAI SERIES PERFORMANCE DATA CONTINUED

Output kW	Full Load Speed [RPM]	Frame Size	Shaft Diam. [mm]	Current @400v		Efficiency		Power Factor		Torque				Noise Level dB (A)	Weight Foot Mount [Kg]
				Full Load [A]	Locked Rotor [%]	Full Load [%]	3/4 Load [%]	Full Load [%]	3/4 Load [%]	Full Load [Nm]	Locked Rotor [% FLT]	Pull Up [% FLT]	Break Down [% FLT]		
11	2930	132MB	38	19.5	1261	90.8	91.0	0.90	0.86	35.8	402	243	390	69	58.5
	2945	160MA	42	19.7	831	90.5	90.6	0.89	0.86	35.6	267	152	345	75	79.0
	1460	132MC	38	20.6	922	90.5	91.2	0.85	0.81	71.9	331	148	353	63	68.0
	1460	160M	42	21.3	698	89.7	90.5	0.83	0.79	71.8	254	176	279	67	83.0
	970	160L	42	23.4	641	89.4	90.0	0.76	0.70	108.2	228	131	239	61	93.0
	730	180L	48	24.1	637	89.2	89.6	0.74	0.67	143.6	201	180	273	64	129
15	2950	160MB	42	26.0	939	92.5	92.7	0.90	0.86	48.5	260	186	343	75	91.0
	1460	160L	42	28.2	829	91.4	91.9	0.84	0.80	97.6	251	164	288	67	102
	975	180L	48	29.2	768	90.4	90.9	0.82	0.78	146.8	242	170	283	61	130
	730	200L	55	31.9	723	90.6	91.0	0.75	0.68	195.6	263	205	318	66	168
18.5	2950	160L	42	31.9	978	91.9	91.2	0.91	0.88	59.9	325	186	338	75	103
	1460	180M	48	33.2	774	91.5	91.9	0.88	0.83	120.4	238	185	298	67	119
	980	200LA	55	36.9	853	91.2	91.2	0.81	0.74	179.4	207	139	320	63	149
22	2950	180M	48	39.5	865	92.3	92.6	0.87	0.85	71.2	274	160	316	75	128
	1460	180L	48	39.4	768	91.7	92.3	0.88	0.84	143.4	242	170	283	67	129
	980	200LB	55	42.6	1031	91.9	92.1	0.83	0.78	213.5	313	156	342	63	162
30	2955	200LA	55	52.9	703	92.0	92.3	0.90	0.88	96.9	205	104	254	75	158
	1470	200L	55	54.2	946	92.9	93.2	0.86	0.82	194.5	325	233	370	70	169
37	2950	200LB	55	63.7	954	92.1	91.8	0.91	0.89	119.5	287	134	348	75	182

TAP SERIES PERFORMANCE DATA

Output kW	Full Load Speed [RPM]	Frame Size	Shaft Diam. [mm]	Current @400v		Efficiency		Power Factor		Torque				Noise Level dB (A)	Weight Foot Mount [Kg]
				Full Load [A]	Locked Rotor [%]	Full Load [%]	3/4 Load [%]	Full Load [%]	3/4 Load [%]	Full Load [Nm]	Locked Rotor [% FLT]	Pull Up [% FLT]	Break Down [% FLT]		
0.75	2890	80A	19	1.64	735	81.6	81.3	0.81	0.72	2.5	315	235	324	64	8.4
	1435	80B	19	1.81	618	83.1	83.4	0.72	0.64	5.0	288	241	296	60	11.3
	945	90S	24	2.01	469	80.0	80.3	0.67	0.58	7.5	231	211	267	58	14.0
1.1	2900	80B	19	2.38	809	83.1	82.6	0.80	0.72	3.6	341	262	351	64	10.2
	1440	90S	24	2.58	674	84.9	85.4	0.72	0.64	7.3	308	248	312	60	15.0
	950	90L	24	2.94	519	81.0	81.1	0.67	0.57	11.1	278	250	298	59	16.2
1.5	2895	90S	24	3.11	825	84.9	85.0	0.82	0.74	4.9	351	210	373	68	14.4
	1440	90L	24	3.60	722	85.7	86.0	0.70	0.61	9.9	385	294	367	60	18.0
	945	100LA	28	3.55	504	82.4	83.8	0.74	0.66	15.1	214	209	262	59	22.0
2.2	2895	90L	24	4.49	808	86.5	86.9	0.82	0.74	7.2	312	226	360	68	16.2
	1450	100LA	28	4.45	793	87.2	87.8	0.82	0.75	14.5	296	248	355	62	23.4
	950	112M	28	5.54	543	84.6	85.3	0.68	0.60	22	208	188	254	59	26.0
3	2915	100L	28	5.60	933	87.4	87.9	0.89	0.84	9.8	318	262	360	71	24.1
	1450	100LB	28	6.20	829	88.2	88.7	0.79	0.71	19.7	339	291	378	62	28.0
	965	132S	38	6.80	593	85.9	86.9	0.74	0.67	29.6	200	175	271	63	39.0
4	2925	112M	28	7.22	1051	88.1	88.5	0.91	0.87	13.1	347	249	398	71	30.2
	1450	112M	28	7.93	854	88.8	89.4	0.82	0.75	26.3	309	266	374	66	32.2
	970	132MA	38	8.88	678	87.4	88.1	0.74	0.67	39.3	237	183	304	63	47.2
5.5	2930	132SA	38	9.98	991	89.5	89.7	0.89	0.85	17.9	318	249	402	69	44.1
	1460	132S	38	10.5	898	89.8	90.5	0.84	0.79	35.9	231	198	350	63	48.0
	970	132MB	38	12.6	738	88.3	88.7	0.71	0.63	53.9	289	220	348	58	55.4
7.5	2925	132SB	38	13.0	1005	90.6	91.4	0.92	0.90	24.5	265	191	362	69	52.0
	1460	132M	38	13.9	889	90.5	91.3	0.86	0.81	49.4	288	175	350	63	58.4
	975	160M	42	15.9	727	89.6	90.3	0.76	0.70	73.5	221	187	297	61	79.6
11	2960	160MA	42	19.7	831	91.9	91.7	0.88	0.84	35.5	267	152	345	75	85.5
	1470	160M	42	20.7	756	92.3	92.8	0.83	0.79	71.4	263	183	299	67	89.0
	975	160L	42	22.2	838	90.9	91.6	0.79	0.73	107.5	279	124	291	61	105
15	2965	160MB	42	26.3	1140	92.4	92.0	0.89	0.85	48.3	392	140	427	75	104
	1470	160L	42	27.6	914	92.6	93.0	0.85	0.81	97.3	300	158	296	67	111
	980	180L	48	30.4	817	91.0	91.0	0.78	0.72	146.8	258	217	339	61	140
18.5	2945	160L	42	31.6	903	92.5	93.2	0.91	0.88	59.9	304	150	301	75	121
	1470	180M	48	33.5	872	92.5	92.8	0.86	0.82	119.9	289	196	333	67	125
	980	200LA	55	36.4	980	91.7	91.5	0.80	0.79	180.3	270	198	370	63	143
22	2950	180M	48	37.5	869	92.7	93.2	0.91	0.9	71.1	274	160	316	75	135
	1475	180L	48	39.3	923	93.4	93.5	0.86	0.81	142.4	306	218	359	67	145
	980	200LB	55	43.1	1050	92.2	92.0	0.80	0.78	214.4	290	220	370	63	162
30	2960	200LA	55	51.2	1012	93.7	93.5	0.90	0.88	96.7	358	189	384	75	165
	1470	200L	55	52.6	968	93.8	94.0	0.88	0.83	194.4	328	216	372	70	175
37	2960	200LA	55	63.4	980	93.7	93.6	0.90	0.88	119.4	360	173	370	75	173



TAI / TAP SERIES MOTOR OUTLINE DIMENSIONS

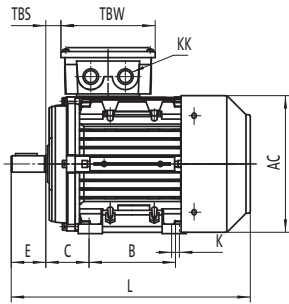

B3

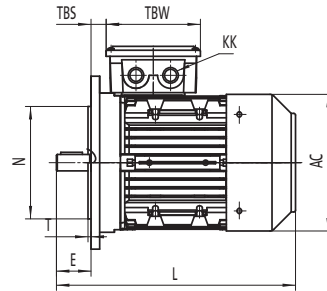
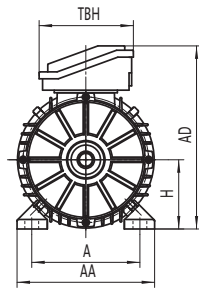

B5

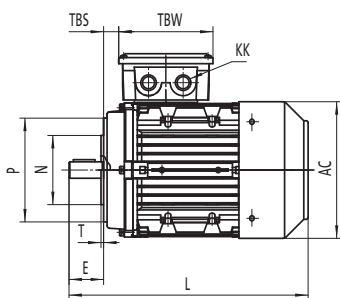
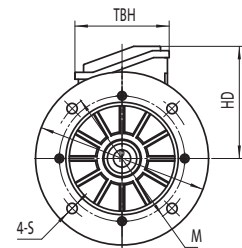

B14

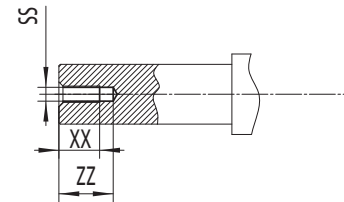
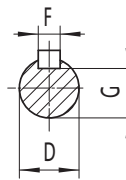
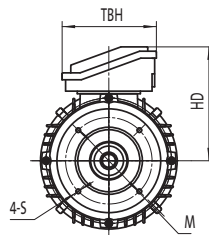

SHAFT

TAI / TAP SERIES DIMENSIONAL DATA

FRAME	Foot Mounting					Shaft							General							
	H	A	B	C	K	D	E	F	G	SS	XX	ZZ	AA	AD	HD	AC	L	TBS	TBW	TBH
TAI 56	56	90	71	36	6	9	20	3	7.2	M3	9	12	112	150	94	110	195	16.5	83	83
TAI 63	63	100	80	40	7	11	23	4	8.5	M4	10	14	124	169	106	122	215	10	98	98
TAI 71	71	112	90	45	7	14	30	5	11	M5	12	17	140	185	114	138	245	16	98	98
TAI 80	80	125	100	50	9	19	40	6	15.5	M6	16	21	160	214	134	158	280	18.5	109	109
TAI 90S/L	90	140	100/125	56	10	24	50	8	20	M8	19	25	175	233	143	177	315/340	20.5	109	109
TAI 100L	100	160	140	63	12	28	60	8	24	M10	22	30	200	260	160	200	377	29	118	118
TAI 112M	112	190	140	70	12	28	60	8	24	M10	22	30	230	283	171	220	400	30	118	118
TAI 132S/M	132	216	140/178	89	12	38	80	10	33	M12	28	37	255	322	190	261	460/498	34	118	118
TAI 160M/L	160	254	210/254	108	15	42	110	12	37	M16	36	45	314	391	231	313	616/662	64	148	148
TAI 180M/L	180	279	241/279	121	15	48	110	14	42.5	M16	36	45	340	440	260	368	730	73	190	190
TAI 200L	200	318	305	133	19	55	110	16	49	M20	42	53	390	460	260	368	745	85	190	190

FRAME	B5					B14A					B5R					B14B				
	N	M	P	S	T	N	M	P	S	T	N	M	P	T	S	N	M	P	T	S
TAI 56	80	100	120	4-7	3	50	65	80	M5	2.5										
TAI 63	95	115	140	4-10	3	60	75	90	M5	2.5										
TAI 71	110	130	160	4-10	3.5	70	85	105	M6	2.5										
TAI 80	130	165	200	4-12	3.5	80	100	120	M6	3	110	130	160	3.5	10	110	130	160	3.5	M8
TAI 90	130	165	200	4-12	3.5	95	115	140	M8	3	110	130	160	3.5	10	110	130	160	3.5	M8
TAI 100	180	215	250	4-15	4	110	130	160	M8	3.5	130	165	200	3.5	12	130	165	200	3.5	M10
TAI 112	180	215	250	4-15	4	110	130	160	M8	3.5	130	165	200	3.5	12	130	165	200	3.5	M10
TAI 132	230	265	300	4-15	4	130	165	200	M10	3.5	180	215	250	4	15	180	215	250	4	M12
TAI 160	250	300	350	4-19	5	180	215	250	M12	4										
TAI 180	250	300	350	4-19	5															
TAI 200	300	350	400	4-19	5															

TAIB SERIES BRAKE MOTORS

0.18kW to 7.5kW

Based on our standard TAI range the TAIB series is stocked from 0.18kW to 7.5kW in 4 pole only with larger ratings and polarities available upon request.



Fail Safe Design

TAIB brake motors are fitted with Intorq brand brakes and are “fail to safe” design, as the brake will engage when the power is disconnected.

Brake Connection

The TAIB three phase motor is fitted with a DC brake and half wave rectifier mounted directly in the terminal box for ease of connection to the AC supply.

- 🔌 230V Delta / 400V Star (3kW & below) fitted with 103V DC brake.
- 🔌 400V Delta / 690V Star (4kW & above) fitted with 180V DC brake.

Hand Release

As standard, all TAIB brake motors are fitted with an emergency hand release.

Mounting Arrangements

TAIB motors are available in identical mounting arrangements to that of our standard TAI aluminium series.

BRAKE MOTOR DATA

kW	Frame Size	Intorq Brake Model	Braking Torque (Nm)	Holding Torque (Nm)	Braking Torque (%) of full load torque	Braking Time (ms)	Release Time (ms)
0.18	63A-4	BFK-457-06	4	6	296%	23	10
0.37	71B-4	BFK-457-06	6	9	231%	23	10
0.55	80A-4	BFK-457-08	8	12	215%	31	15
0.75	80B-4	BFK-457-08	12	17	240%	31	15
1.1	90S-4	BFK-457-10	16	23	216%	50	31
1.5	90L-4	BFK-457-10	23	33	232%	50	31
2.2	100LA-4	BFK-457-12	32	46	219%	64	39
3	100LB-4	BFK-457-12	40	58	202%	64	39
4	112M-4	BFK-457-14	60	87	227%	51	26
5.5	132S-4	BFK-457-16	70	101	195%	70	40
7.5	132M-4	BFK-457-16	100	145	202%	70	40

Other kW and speed options are available upon request.



TAIB SERIES MOTOR OUTLINE DIMENSIONS

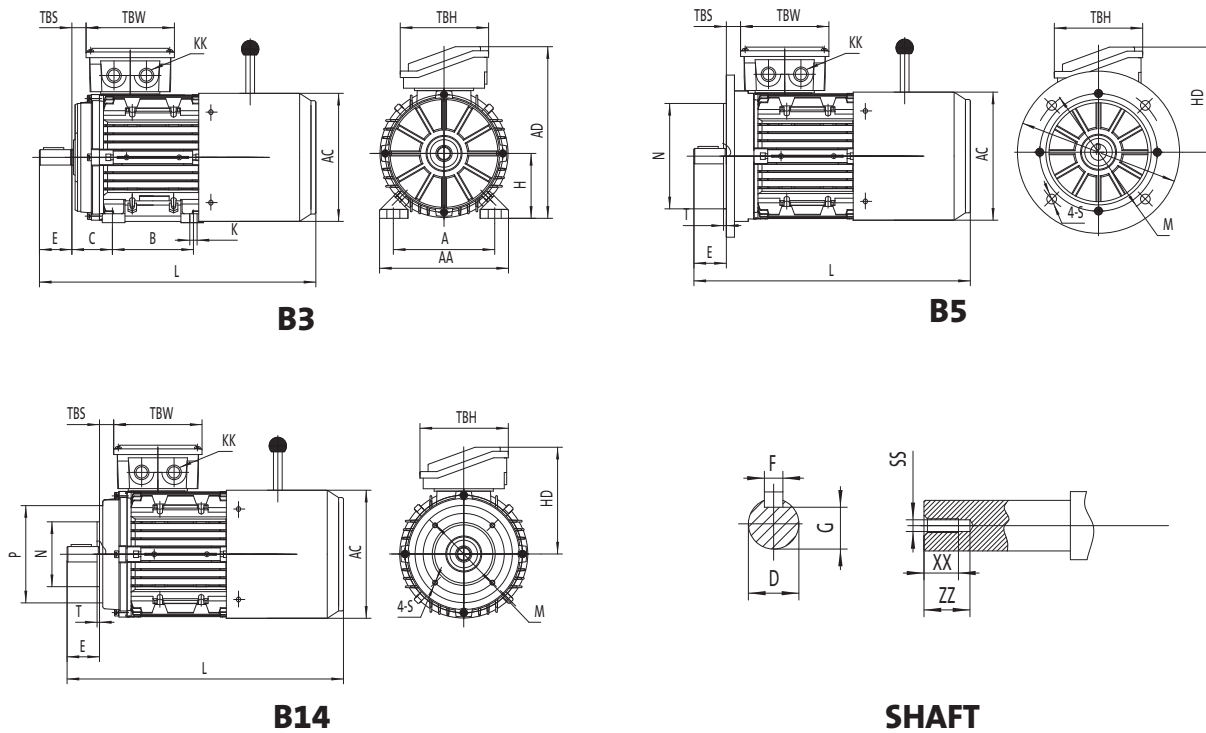

TAIB SERIES DIMENSIONAL DATA

FRAME	Foot Mounting					Shaft							General							
	H	A	B	C	K	D	E	F	G	SS	XX	ZZ	AA	AD	HD	AC	L	TBS	TBW	TBH
TAIB 63	63	100	80	40	7	11	23	4	8.5	M4	10	14	124	169	106	121	265	14	94	94
TAIB 71	71	112	90	45	7	14	30	5	11	M5	12	17	140	184	113	139	301	20	94	94
TAIB 80	80	125	100	50	9	19	40	6	15.5	M6	16	21	160	214	134	158	341	18.5	109	109
TAIB 90S/L	90	140	100/125	56	10	24	50	8	20	M8	19	25	175	233	143	177	366/391	20.5	109	109
TAIB 100L	100	160	140	63	12	28	60	8	24	M10	22	30	200	260	160	200	440	29	118	118
TAIB 112M	112	190	140	70	12	28	60	8	24	M10	22	30	230	283	171	220	465	30	118	118
TAIB 132S/M	132	216	140/178	89	12	38	80	10	33	M12	28	37	255	322	190	261	543/581	34	118	118

FRAME	B5					B14A					B5R					B14B				
	N	M	P	S	T	N	M	P	S	T	N	M	P	T	S	N	M	P	T	S
TAIB 63	95	115	140	4-10	3	60	75	90	M5	2.5										
TAIB 71	110	130	160	4-10	3.5	70	85	105	M6	2.5										
TAIB 80	130	165	200	4-12	3.5	80	100	120	M6	3	110	130	160	3.5	10	110	130	160	3.5	M8
TAIB 90S/L	130	165	200	4-12	3.5	95	115	140	M8	3	110	130	160	3.5	10	110	130	160	3.5	M8
TAIB 100L	180	215	250	4-15	4	110	130	160	M8	3.5	130	165	200	3.5	12	130	165	200	3.5	M10
TAIB 112M	180	215	250	4-15	4	110	130	160	M8	3.5	130	165	200	3.5	12	130	165	200	3.5	M10
TAIB 132S/M	230	265	300	4-15	4	130	165	200	M10	3.5	180	215	250	4	15	180	215	250	4	M12

0.75kW to 315kW – Frame 80 to 355

Techtop's TCI/TCP cast iron series motors combine superior electrical characteristics, high quality design and the robust strength of cast iron, making this series ideal for all industrial applications.



Operating parameters

Standard TCI/TCP series motors are designed with the following parameters:

- ⚙ 380V to 415V, 50Hz & 440V to 480V, 60Hz supply
- ⚙ Continuous (S1) duty
- ⚙ Ambient temperatures up to 40°C
- ⚙ Installation up to 1000 MASL

Connection

- ⚙ 230V Delta / 400V Star (3kW & below)
- ⚙ 400V Delta / 690V Star (4kW & above)

Standards

Dimensions and rated outputs for the TCI/TCP series conform to Australian Standard AS/NZS 1359 and International Standards IEC 60034 and IEC 60072.

Standard & High Efficiency

The TCI range complies with MEPS2 requirements of AS/NZS 1359.5:2004 Table A2 (**Standard Efficiency**). The TCP range complies with MEPS2 requirements of AS/NZS 1359.5:2004 Table A3 (**High Efficiency**). Motors are tested in accordance with Test Method A of AS/NZS 1359.102.3 as per IEC 60034-2-1.

Insulation class

TCI/TCP motors are insulated with Class F materials and limited to Class B temperature rise. The windings are spike resistant making them suitable for use with VVVF drives.

Thermistors

As standard all TCI/TCP series motors from 160 frame and above are fitted with one set of PTC thermistors. The thermistor termination is located in the main terminal box and has a trip temperature of 150°C as standard. Additional 130°C thermistors can be fitted as an option for alarm connection. Thermistors are available as an option for smaller frame sizes.

IP Protection

The standard degree of enclosure protection is IP 55 (increased IP protection is available). Shafts are fitted with an oil seal as standard.

Multi-mount design

TCI/TCP series motors from frame size 80 to 280 are fitted with detachable feet. The multi-mount design allows for the motor feet to be removed and repositioned to either side to produce a side mounted terminal box.

Terminal box

The terminal box is manufactured from cast iron and is mounted on top of the motor as standard. Terminal box is separate to the motor body and can be rotated in 90° increments.

Surface Finish

As standard TCI/TCP motors are painted with high quality alkyd enamel with the final colour being RAL 9005 Jet Black. Other colours are available upon request.

Bearings

Bearings fitted are high quality NSK (or equivalent) bearings with C3 diametrical clearances. As standard, frame sizes 80 to 132 have sealed for life deep groove ball bearings. Frame sizes 160 to 355 have re-greaseable bearings with facilities to replenish the grease during operation. Grease nipples are fitted to the top of the end shields with a grease relief fitted at the bottom.

Frame size	Bearing	
	D.E.	N.D.E
80	6204 ZZ C3	
90	6205 ZZ C3	
100	6206 ZZ C3	
112	6306 ZZ C3	
132	6308 ZZ C3	
160	6309 C3	
180	6311 C3	
200	6312 C3	
225	6313 C3	
250	6314 C3	
280	6316 C3	
315 (2P)	6317 C3	
315 (4/6/8)	NU319 C3	6319 C3
355 (2P)	6319 C3	
355 (4/6/8)	NU322 C3	6322 C3



Part Number Logic

Detailed below is the part number logic which should be specified when placing orders. The part number is composed in accordance with the following example:

T	C	4	B	0	2	2	5	TCI	/A05
1	2	3	4	5 - 7		8	9 - 12	13 - 16	

Position 1

T = Techtop

Position 2

A = Aluminium

C = Cast Iron

Position 3

2 = 2 Pole

4 = 4 Pole

6 = 6 Pole

8 = 8 Pole

Position 4

A = less than 0.99kW

B = 1.0kW to 9.9kW

C = 10.0kW to 99.9kW

D = 100kW to 999kW

Position 5 to 7

Output kW

Position 8

Mounting position

1 = V1

3 = B3

4 = B3/5

5 = B5

6 = B3/B14A

7 = B14A

8 = B3/B14B

9 = B14B

Position 9 to 12

TCI = Cast iron Std Eff.

TCP = Cast iron Hi-Eff.

TCIM = Cast iron Mine Spec.

Position 13 to 16

H = Class H insulation

A05 = 1000V

Vibration

Vibration levels are within Level N (normal) limits of vibration severity as per IEC 60034 – 14:2007 which are listed below:

Vibration Grade	Frame size	56 - 132	160 - 280	315 - 355
	Mounting Type	(mm/s)	(mm/s)	(mm/s)
A	Suspension	1.5	2.2	2.8
	Rigid Mount	1.3	1.8	2.3

Conduit Entries

Frame Size	Entry Size	Number of Entries
80	M20 x 1.5	2
90	M20 x 1.5	2
100	M20 x 1.5	2
112	M25 x 1.5	2
132	M25 x 1.5	2
160*	M32 x 1.5	2
180*	M32 x 1.5	2
200*	M50 x 1.5	2
225*	M50 x 1.5	2
250*	M50 x 1.5	2
280*	M50 x 1.5	2
315*	M63 x 1.5	2
355*	M63 x 1.5	2

*Frames fitted with 1 X M20 cable gland for thermistor termination.

Noise Level

Noise levels comply with the limits shown in IEC 60034.9 and AS1359.109 standards.

Output kW	Sound pressure dB(A) @ 1 metre no load			
	2 Pole	4 Pole	6 Pole	8 Pole
0.75	64	60	58	55
1.1	64	60	59	55
1.5	68	60	59	55
2.2	68	62	59	55
3	71	62	63	58
4	71	66	63	58
5.5	69	63	58	58
7.5	69	63	61	58
11	75	67	61	58
15	75	67	61	61
18.5	75	67	63	66
22	75	67	63	66
30	75	70	66	66
37	75	70	66	66
45	75	70	66	66
55	77	70	66	69
75	78	73	73	69
90	78	73	73	69
110	80	77	73	69
132	80	77	73	79
160	80	77	82	79
200	80	77	82	79
250	86	84	82	-
315	86	84	-	-

GREASE

TCI bearings are lubricated with polyurea (Mobil Polyrex EM) based bearing grease suitable for operation in ambient temperatures from -20°C to +55°C. Bearings are prepacked with grease but it is recommended to lubricate the bearings one hour after commissioning.

RECOMMENDED BEARING MAINTENANCE

Frame	Bearing	Grease Qty (g)	Interval Hours			
			2P	4P	6P	8P
160	6309 C3	15	6,600	11,000	14,000	16,200
180	6311 C3	18	6,100	10,600	14,000	15,250
200	6312 C3	20	5,200	10,200	14,100	15,000
225	6313 C3	25	4,900	9,600	13,600	15,000
250	6314 C3	38	2,600	9,200	13,200	14,600
280	6316 C3	42	2,100	9,000	12,800	14,000
315 (2P)	6317 C3	44	2,000	–	–	–
315 (4/6/8)	NU/6319 C3	48	–	6,400	9,300	12,000
355 (2P)	6319 C3	48	1,900	–	–	–
355 (4/6/8)	NU/6322 C3	68	–	4,400	8,300	11,000

RADIAL & AXIAL LOADS

The table below details the permissible force that can be applied to the motor shaft and are applicable for horizontal mounting only. The values shown are calculated on a basic bearing life of L_{10} of 40,000 hours.

Frame size	Permissible Radial Load (N)				Permissible Axial Load (N)			
	2 Pole	4 Pole	6 Pole	8 Pole	2 Pole	4 Pole	6 Pole	8 Pole
80	470	595	690	750	395	540	655	635
90	485	625	720	785	420	570	685	690
100	710	890	1,035	1,150	570	780	940	1,075
112	950	1,240	1,420	1,580	790	1,085	1,310	1,520
132	1,420	1,820	2,100	2,325	1,160	1,590	1,915	2,210
160	1,800	2,350	2,720	3,040	1,480	2,035	2,450	2,810
180	2,490	3,200	3,780	4,215	1,990	2,710	3,270	3,760
200	2,915	3,750	4,350	4,835	2,225	3,065	3,710	4,235
225	3,270	4,000	4,700	5,210	2,460	3,390	4,130	4,750
250	3,590	4,650	5,400	5,980	2,725	3,780	4,575	5,225
280	3,700	8,100	9,375	10,300	3,280	4,560	5,590	6,375
315 (2P)	4,500	-	-	-	3,825	-	-	-
315 (4/6/8)	-	15,800	17,950	19,750	-	4,855	5,895	6,780
355 (2P)	4,560	-	-	-	3,980	-	-	-
355 (4/6/8)	-	22,145	25,360	27,890	-	6,135	7,395	8,555



0.75kW to 315kW – Frame 80 to 355

Techtop's TCIM mining specification cast iron series motors are designed for severe duty applications and harsh environments.



Based on the TCI series our TCIM high specification motor has the identical electrical performance to the TCI series with additional mechanical features as detailed below:

- IP66 protection
- Class H insulation with Class B rise
- Oil seals fitted at both ends
- Rotating slinger at both ends
- Cast iron fan
- Cast iron fan cowl
- Sintered bronze porous drain plugs
- Stainless steel name plate
- Epoxy paint finish
- Tropic Proof

Please refer to the TCI performance data as detailed on pages 24 & 25 of this catalogue.

Surface Finish

TCIM motors are subject to a two pack epoxy coating system with the final colour being RAL 2008 Bright Red Orange.

Operating parameters

High specification TCIM series motors are designed with the following parameters:

- 380V to 415V, 50Hz & 440V to 480V 60Hz supply
- Continuous (S1) duty
- Ambient temperatures up to 50°C
- Installation up to 1000 MASL
- Service factors up to 1.25

Available options

- Insulated bearing & earth brush
- Winding RTD's
- Bearing RTD's
- Force ventilation
- Auxiliary terminal box

Dimensions

Please refer to page 27 of this catalogue.

TCI / TCIM SERIES PERFORMANCE DATA

Output kW	Full Load Speed [RPM]	Frame Size	Shaft Dia [mm]	Current @ 400v		Efficiency		Power Factor		Torque				Noise Level dB (A)	Weight Foot Mount [Kg]
				Full Load [A]	Locked Rotor [%]	Full Load [%]	3/4 Load [%]	Full Load [%]	3/4 Load [%]	Full Load [Nm]	Locked Rotor [% FLT]	Pull Up [% FLT]	Break Down [% FLT]		
0.75	2880	80A	19	1.76	687	80.1	80.2	0.79	0.71	2.5	292	196	302	64	16
	1420	80B	19	1.94	550	81.1	81.5	0.69	0.60	5	303	270	310	60	18
	940	90S	24	2.22	444	76.3	75.7	0.65	0.54	7.6	225	196	252	58	20
	690	100LA	28	2.21	363	72.3	73.3	0.68	0.58	10.4	177	175	213	55	34
1.1	2880	80A	19	2.39	758	81.2	81.3	0.82	0.74	3.6	283	186	285	64	17
	1420	90S	24	2.57	618	82.8	83.8	0.75	0.67	7.4	296	247	297	60	22
	950	90L	24	2.98	487	78.4	78.7	0.69	0.60	11	207	180	245	59	29
	690	100LA	28	3.17	390	74.8	75.2	0.67	0.57	15.1	198	192	230	55	35
1.5	2880	90S	24	3.19	690	83.1	83.5	0.83	0.75	5.0	276	187	308	68	21
	1440	90L	24	3.44	713	85.5	86.1	0.76	0.68	9.9	316	240	313	60	26
	945	100LA	28	3.71	472	80.1	82	0.74	0.66	15.1	172	161	225	59	34
	700	112M	28	4.18	403	78.4	79.3	0.68	0.59	20.4	182	180	212	55	42
2.2	2890	90L	24	4.61	811	84	84.4	0.83	0.75	7.2	300	222	318	68	22
	1440	100LA	28	4.55	726	85.8	86.6	0.82	0.76	14.6	260	218	305	62	36
	950	112M	28	5.36	547	82.8	83.9	0.73	0.64	22	220	181	271	59	40
	710	132S	38	5.95	420	80.0	80.6	0.67	0.58	29.4	186	174	233	55	68
3	2900	100L	28	5.59	920	87.0	87.6	0.90	0.87	9.9	309	249	351	71	35
	1445	100LB	28	6.27	760	86.0	86.6	0.80	0.73	19.8	239	244	325	62	37
	960	132S	38	6.42	601	85.5	86.6	0.76	0.70	29.6	188	157	258	63	65
	715	132M	38	7.8	529	82.7	83.1	0.70	0.61	39.9	231	203	274	58	77
4	2915	112M	28	7.56	960	87.4	87.7	0.89	0.84	13.1	332	208	365	71	47
	1440	112M	28	8.17	781	87.5	88.2	0.82	0.75	26.4	257	231	335	66	51
	960	132MA	38	9.21	583	84.7	85.6	0.74	0.68	39.6	200	165	257	63	67
	720	160MA	42	9.56	556	85.5	86.0	0.71	0.63	53.0	232	169	254	58	116
5.5	2910	132SA	38	10.3	823	87.8	88.3	0.89	0.85	18.0	244	195	343	69	61
	1460	132SA	38	11.0	856	88.1	88.5	0.83	0.77	35.9	217	193	350	63	65
	960	132MB	38	12.4	654	86.3	87.5	0.75	0.69	54.5	240	184	261	58	68
	720	160MB	42	14.9	600	85.8	84.7	0.63	0.61	74.0	230	190	260	58	147
7.5	2920	132SA	38	13.9	1029	89.2	89.6	0.89	0.86	24.5	314	202	366	69	66
	1450	132M	38	14.3	823	89.5	90.4	0.85	0.82	49.4	299	117	295	63	77
	980	160M	42	17.5	855	89.7	89.4	0.71	0.63	73.0	331	194	336	61	120
	720	160L	42	18.6	600	87.2	86.9	0.67	0.64	100.1	240	190	270	58	147
11	2950	160MA	42	19.5	858	89.9	90.2	0.91	0.89	35.6	260	93	302	75	113
	1470	160M	42	20.4	838	91.7	91.7	0.86	0.81	71.3	287	203	329	67	125
	975	160L	42	23.8	818	89.4	89.7	0.75	0.68	107.5	309	140	152	61	135
	730	180L	48	23.8	660	88.8	88.7	0.75	0.69	145.9	230	200	280	58	183
15	2950	160MB	42	25.8	901	91.8	92.1	0.92	0.90	48.4	257	132	316	75	132
	1470	160L	42	27.4	881	91.1	91.5	0.88	0.84	97.4	253	177	316	67	140
	980	180L	48	31.4	882	89.6	88.9	0.77	0.70	145.7	267	153	322	61	183
	730	200L	55	30.6	660	90.0	90.1	0.78	0.76	198.9	220	200	290	61	240
18.5	2950	160L	42	32.0	976	92.1	92.6	0.92	0.91	59.8	302	140	332	75	146
	1470	180M	48	33.2	786	91.8	92	0.88	0.84	120.1	254	194	311	67	158
	980	200LA	55	36.9	853	91.2	91.2	0.81	0.74	179.4	207	139	320	63	232
	730	225S	60	38.7	660	90.7	90.4	0.76	0.72	243.7	220	200	320	66	315
22	2950	180M	48	39.1	843	91.2	91	0.90	0.88	71.2	266	163	330	75	177
	1465	180L	48	38.9	767	91.9	92.5	0.89	0.86	143.1	225	155	269	67	183
	980	200LB	55	42.6	1031	91.9	92.1	0.83	0.78	213.5	313	156	342	63	250
	740	225M	60	43.5	660	91.2	91.4	0.80	0.78	289.7	210	190	310	66	348



TCI / TCIM SERIES PERFORMANCE DATA CONTINUED

Output kW	Full Load Speed [RPM]	Frame Size	Shaft Dia [mm]	Current @ 400v		Efficiency		Power Factor		Torque				Noise Level dB (A)	Weight Foot Mount [Kg]
				Full Load [A]	Locked Rotor [%]	Full Load [%]	3/4 Load [%]	Full Load [%]	3/4 Load [%]	Full Load [Nm]	Locked Rotor [% FLT]	Pull Up [% FLT]	Break Down [% FLT]		
30	2955	200LA	55	52.9	703	92.0	92.3	0.90	0.88	96.9	205	104	254	75	233
	1480	200L	55	57.2	814	92.5	92.7	0.82	0.76	193.5	237	191	295	70	242
	985	225M	60	54.9	815	91.9	92.4	0.86	0.83	290.5	264	151	257	66	335
	740	250M	65	61.5	660	92.1	91.6	0.76	0.71	392.4	210	190	270	66	397
37	2955	200LB	55	64.9	759	92.7	93.1	0.90	0.88	119.6	244	144	260	75	246
	1475	225S	60	65.4	743	91.2	90.7	0.85	0.82	239.1	222	147	243	70	315
	980	250M	65	68.7	646	93.2	93.3	0.85	0.82	359.2	186	135	232	66	398
	740	280S	75	73.5	660	92.7	92.5	0.78	0.74	484.0	210	180	250	66	500
45	2955	225M	55	77.6	744	93.2	93.4	0.91	0.89	145.2	273	113	251	75	322
	1475	225M	60	85.1	695	93.1	92.9	0.83	0.78	290.5	207	187	333	70	352
	985	280S	75	81.5	850	92.7	93.0	0.86	0.82	434.7	284	156	272	66	505
	740	280M	75	88.9	660	93.2	93.1	0.78	0.77	584.7	200	180	250	66	594
55	2970	250M	60	93.3	892	94.5	94.3	0.91	0.90	176.8	302	142	299	77	420
	1480	250M	65	98.7	805	93.6	93.9	0.86	0.83	354.4	264	167	268	70	420
	985	280M	75	99.0	897	93.5	93.6	0.87	0.83	531.3	321	181	311	66	596
	740	315S	80	107.2	750	93.7	93.1	0.79	0.76	709.8	200	180	240	69	1025
75	2970	280S	65	125.3	898	93.9	93.9	0.93	0.93	241.0	256	105	281	78	572
	1480	280S	75	127.7	756	94.9	95.2	0.90	0.89	482.5	254	211	237	73	570
	980	315S	80	128.9	790	94.4	94.1	0.89	0.86	730.8	210	190	250	73	809
	740	315M	80	145.2	770	94.4	94.0	0.79	0.75	967.8	200	180	230	69	1108
90	2970	280M	65	148.3	1009	94.5	94.3	0.93	0.92	289.1	294	123	302	78	637
	1485	280M	75	152.9	860	94.4	94.8	0.92	0.90	578.7	297	229	260	73	658
	980	315M	80	152.3	800	94.8	94.2	0.90	0.88	877.0	200	180	230	73	962
	740	315LA	80	171.5	780	94.7	94.5	0.80	0.78	1161.4	200	180	220	69	1155
110	2980	315S	65	185.5	770	95.1	95.2	0.90	0.88	357.3	190	170	225	80	1008
	1480	280MB	75	188.4	773	94.7	94.6	0.89	0.88	709.8	246	172	308	73	658
	1485	315S	80	185.1	780	95.3	95.1	0.91	0.89	709.8	210	180	230	77	1049
	980	315LA	80	185.5	770	95.1	95.3	0.90	0.87	1071.9	200	180	235	73	989
132	2980	315M	65	219.5	760	95.4	95.2	0.91	0.89	428.7	190	160	220	80	1062
	1485	315M	80	222.8	700	95.0	94.2	0.90	0.87	848.9	248	164	323	77	1049
	980	315LB	80	224.4	800	95.4	95.1	0.89	0.87	1286.2	200	175	230	73	1082
160	2980	315LA	65	268.7	780	95.5	95.4	0.90	0.90	518.8	205	180	240	80	1222
	1485	315LA	80	265.2	790	95.7	95.5	0.91	0.91	1032.4	200	180	230	77	1222
	985	355MA	100	265.5	760	95.6	95.3	0.91	0.89	1559.0	220	195	238	82	1580
	745	355MB	100	287.3	780	95.7	95.4	0.84	0.82	2050.9	200	180	235	79	1740
200	2985	315LB	65	339.7	790	95.5	95.2	0.89	0.88	648.5	215	170	240	80	1240
	1490	315LB	80	335.2	770	95.7	95.6	0.90	0.90	1290.5	200	180	235	77	1190
	985	355MB	100	336.0	760	95.6	95.7	0.90	0.88	1948.8	210	190	245	82	1760
	745	355LB	100	350.8	770	95.7	95.5	0.86	0.85	2563.6	205	185	235	79	1990
250	2985	355M	75	419.8	780	95.5	95.2	0.90	0.89	810.6	200	180	240	86	1780
	1490	355M	100	423.7	790	95.7	95.4	0.89	0.87	1613.0	230	190	260	84	1820
	985	355LB	100	424.1	780	95.6	95.2	0.89	0.86	2436.0	210	190	250	82	1990
315	2985	355LB	75	531.8	740	95.0	95.6	0.90	0.86	1021.4	225	195	240	86	1780
	1490	355LB	100	532.3	758	95.8	96.1	0.89	0.89	2020.3	275	185	255	84	1700

TCP SERIES PERFORMANCE DATA

Output kW	Full Load Speed [RPM]	Frame Size	Shaft Dia [mm]	Current @ 400v		Efficiency		Power Factor		Torque				Noise Level dB (A)	Weight Foot Mount [Kg]
				Full Load [A]	Locked Rotor [%]	Full Load [%]	3/4 Load [%]	Full Load [%]	3/4 Load [%]	Full Load [Nm]	Locked Rotor [% FLT]	Pull Up [% FLT]	Break Down [% FLT]		
0.75	2890	80A	19	1.64	735	81.6	81.3	0.81	0.72	2.5	315	235	324	64	15.2
	1435	80B	19	1.81	618	83.1	83.4	0.72	0.64	5.0	288	241	296	60	18.2
	945	90S	24	2.01	469	80.0	80.3	0.67	0.58	7.5	231	211	267	58	21.5
1.1	2900	80B	19	2.38	809	83.1	82.6	0.80	0.72	3.6	341	262	351	64	17.1
	1440	90S	24	2.58	674	84.9	85.4	0.72	0.64	7.3	308	248	312	60	23.0
	950	90L	24	2.94	519	81.0	81.1	0.67	0.57	11.1	278	250	298	59	25.5
1.5	2895	90S	24	3.11	825	84.9	85.0	0.82	0.74	4.9	351	210	373	68	21.5
	1440	90L	24	3.60	722	85.7	86.0	0.70	0.61	9.9	385	294	367	60	26.3
	945	100LA	28	3.55	504	82.4	83.8	0.74	0.66	15.1	214	209	262	59	33.5
2.2	2895	90L	24	4.49	808	86.5	86.9	0.82	0.74	7.2	312	226	360	68	24.6
	1450	100LA	28	4.45	793	87.2	87.8	0.82	0.75	14.5	296	248	355	62	35.5
	950	112M	28	5.54	543	84.6	85.3	0.68	0.60	22	208	188	254	59	40.0
3	2915	100L	28	5.60	933	87.4	87.9	0.89	0.84	9.8	318	262	360	71	35.5
	1450	100LB	28	6.20	829	88.2	88.7	0.79	0.71	19.7	339	291	378	62	38.5
	965	132S	38	6.80	593	85.9	86.9	0.74	0.67	29.6	200	175	271	63	59.0
4	2925	112M	28	7.22	1051	88.1	88.5	0.91	0.87	13.1	347	249	398	71	44.5
	1450	112M	28	7.93	854	88.8	89.4	0.82	0.75	26.3	309	266	374	66	47.0
	970	132MA	38	8.88	678	87.4	88.1	0.74	0.67	39.3	237	183	304	63	75.5
5.5	2930	132SA	38	9.98	991	89.5	89.7	0.89	0.85	17.9	318	249	402	69	63.2
	1460	132S	38	10.5	898	89.8	90.5	0.84	0.79	35.9	231	198	350	63	68.3
	970	132MB	38	12.6	738	88.3	88.7	0.71	0.63	53.9	289	220	348	58	76.3
7.5	2925	132SB	38	13.0	1005	90.6	91.4	0.92	0.90	24.5	265	191	362	69	70.0
	1460	132M	38	13.9	889	90.5	91.3	0.86	0.81	49.4	288	175	350	63	79.0
	960	160M	42	16.2	750	89.1	90.3	0.75	0.70	74.6	230	187	280	61	120
11	2960	160MA	42	19.3	932	91.3	91.8	0.90	0.87	35.5	225	100	341	75	121
	1470	160M	42	19.8	846	91.8	92.3	0.87	0.83	71.4	300	60	301	67	128
	960	160L	42	22.3	730	91.2	90.8	0.75	0.78	109.4	250	200	280	61	134
15	2955	160MB	42	26.2	1038	92.1	92.1	0.90	0.87	48.4	331	175	356	75	123
	1470	160L	42	26.5	945	92.6	92.9	0.88	0.85	97.2	263	115	317	67	140
	960	180L	48	30.1	800	91.2	92.0	0.79	0.77	149.2	250	140	280	61	184
18.5	2955	160L	42	31.1	950	92.7	93.2	0.93	0.91	59.8	279	117	331	75	160
	1475	180M	48	33.3	875	92.9	93.2	0.86	0.81	119.7	263	203	339	67	160
	980	200LA	55	36.2	928	91.7	92.0	0.8	0.74	179.5	289	60	321	63	188
22	2960	180M	48	37.9	956	93.0	93.3	0.90	0.88	71.0	246	180	345	75	183
	1475	180L	48	38.9	978	93.8	94.0	0.87	0.83	142.3	305	194	341	67	186
	980	200LB	55	42.1	1021	92.7	92.8	0.81	0.76	213.4	277	167	348	63	250
30	2965	200LA	55	51.6	889	94.0	94.2	0.89	0.86	96.5	289	183	332	75	247
	1480	200LA	55	58.4	852	93.6	93.5	0.79	0.72	193.3	287	267	370	70	245
	980	225M	60	53.0	661	92.8	93.6	0.88	0.86	291.8	193	201	221	66	252
37	2965	200LB	55	63.2	793	93.8	94.2	0.9	0.88	119.3	273	152	288	75	268
	1480	225S	60	65.0	919	94.3	94.5	0.87	0.84	238.3	271	142	286	70	320
	975	250M	65	67.3	700	93.3	94.0	0.85	0.83	362.4	180	130	200	66	399
45	2965	225M	55	74.9	638	94.4	94.7	0.92	0.91	144.9	176	66	262	75	322
	1480	225M	60	79.1	898	94.8	94.9	0.87	0.83	290.0	275	170	291	70	350
	990	280S	75	80.1	1028	93.9	93.9	0.86	0.82	433.9	361	242	347	66	410
55	2970	250M	60	92.4	1004	94.9	94.8	0.91	0.88	176.6	293	183	351	77	420
	1485	250M	65	98.0	884	95.1	95.2	0.85	0.81	353.8	291	192	310	70	460
	990	280M	75	98.3	1001	94.5	94.3	0.85	0.81	530.2	350	192	341	66	520
75	2975	280S	65	125.2	1057	95.2	95.0	0.91	0.89	240.4	298	164	360	78	630
	1490	280S	75	130.6	1046	95.0	95.3	0.87	0.83	480.6	358	208	340	73	620
	980	315S	80	139.6	750	94.6	94.8	0.82	0.8	730.9	210	130	235	73	860
90	2975	280M	65	149.7	1100	95.1	94.9	0.91	0.90	288.5	320	285	351	78	650
	1490	280M	75	158.6	1074	95.9	95.8	0.85	0.81	576.7	355	220	361	73	673
	980	315M	80	166.9	760	94.9	95.0	0.82	0.81	877.0	200	130	240	73	970
110	2960	315S	65	185.3	700	95.5	94.6	0.90	0.88	354.9	210	140	230	80	980
	1490	315S	80	190.0	866	95.8	95.6	0.87	0.84	704.8	333	231	383	77	1030
	985	315L	80	203.6	760	95.1	95.4	0.82	0.80	1071.9	220	145	250	73	1070
132	2960	315M	65	185.3	710	95.2	95.5	0.90	0.88	354.9	200	140	235	80	1100
	1490	315M	80	224.3	906	95.8	95.9	0.89	0.86	845.8	366	103	383	77	1070
	980	315LA	80	243.6	780	95.4	95.7	0.82	0.81	1286.3	220	148	245	73	1196



TCI / TCP / TCIM SERIES MOTOR OUTLINE DIMENSIONS

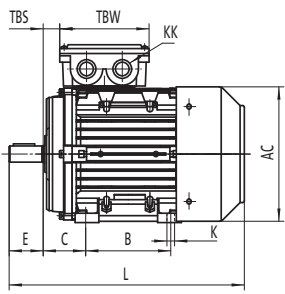

B3

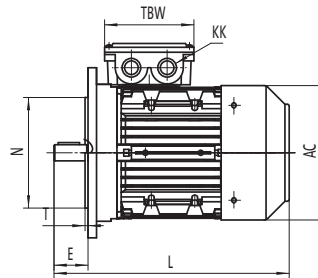
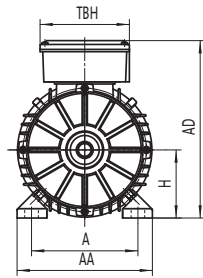

B5

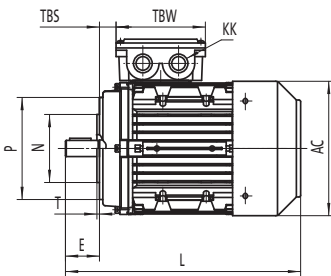
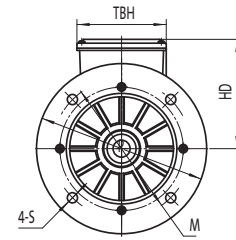

B14

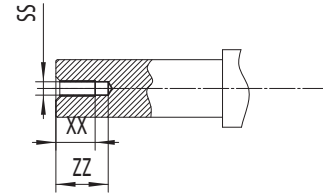
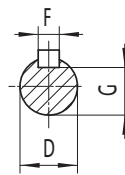
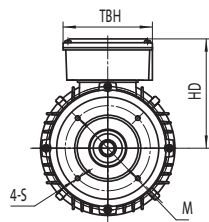

SHAFT

TCI / TCP / TCIM SERIES DIMENSIONAL DATA

Frame Size	Foot Mounting					Shaft					General								
	H	A	B	C	K	D	E	F	G	SS	AA	AD	HD	AC	L	TBS	TBW	TBH	
80	80	125	100	50	9	19	40	6	15.5	M6	154	209	129	158	290	48	105	105	
90S/L	90	140	100/125	56	10	24	50	8	20	M8	178	231	150	176	320/345	49	114	114	
100	100	160	140	63	12	28	60	8	24	M10	203	251	151	199	385	76	114	114	
112	112	190	140	70	12	28	60	8	24	M10	231	292	180	220	405	73	134	134	
132S/M	132	216	140/178	89	12	38	80	10	33	M12	264	330	198	259	457/505	62	134	134	
160M/L	160	254	210/254	108	15	42	110	12	37	M16	316	404	244	313	605/650	91	162	162	
180M/L	180	279	241/279	121	15	48	110	14	42.5	M16	361	442	262	360	687/725	160/180	162	187	
200L	200	318	305	133	19	55	110	16	49	M20	392	500	300	399	769	193	186	233	
225S	4,8	225	356	286	149	19	60	140	18	53	M20	438	557	332	465	810	199	186	233
225M	2	225	356	311	149	19	55	110	16	49	M20	438	557	332	465	805	212	186	233
	4,6,8	225	356	311	149	19	60	140	18	53	M20	438	557	332	465	835	212	186	233
250M	2	250	406	349	168	24	60	140	18	53	M20	484	616	366	506	915	234	218	260
	4,6,8	250	406	349	168	24	65	140	18	58	M20	484	616	366	506	915	234	218	260
280S/M	2	280	457	368/419	190	24	65	140	18	58	M20	557	673/690	393/410	559	984/1035	265/277	218/245	260/280
	4,6,8	280	457	368/419	190	24	75	140	20	67.5	M20	557	673/690	393/410	559	984/1035	265/277	218/245	260/280
315S	2	315	508	406	216	28	65	140	18	58	M20	628	825	510	682	1205	200	290	350
	4,6,8	315	508	406	216	28	80	170	22	71	M20	628	825	510	682	1235	200	290	350
315M/L	2	315	508	457/508	216	28	65	140	18	58	M20	628	825	510	682	1355	200	290	350
	4,6,8	315	508	457/508	216	28	80	170	22	71	M20	628	825	510	682	1385	200	290	350
355M/L	2	355	610	560/630	254	28	75	140	20	67.5	M20	740	1010	655	820	1500	140	330	380
	4,6,8	355	610	560/630	254	28	100	210	28	90	M24	740	1010	655	820	1570	140	330	380

Frame Size	B5				
	N	M	P	S	T
80 - 90	130	165	198	4-12	3.5
100 - 112	180	215	250	4-15	4
132	230	265	300	4-15	4
160 - 180	250	300	350	4-19	5
200	300	350	400	4-19	5
225	350	400	450	8-19	5
250 - 280	450	500	550	8-19	5
315	550	600	660	8-24	6
355	680	740	800	8-24	6

Frame Size	B14A				
	N	M	P	S	T
80	80	100	118	M6	3
90	95	115	138	M8	3
100 - 112	110	130	158	M8	3.5
132	130	165	198	M10	3.5

MPX SERIES / IE4 PREMIUM

11kW to 355kW – Frame 160 to 355

Techtop's MPX is the newest edition to the range.

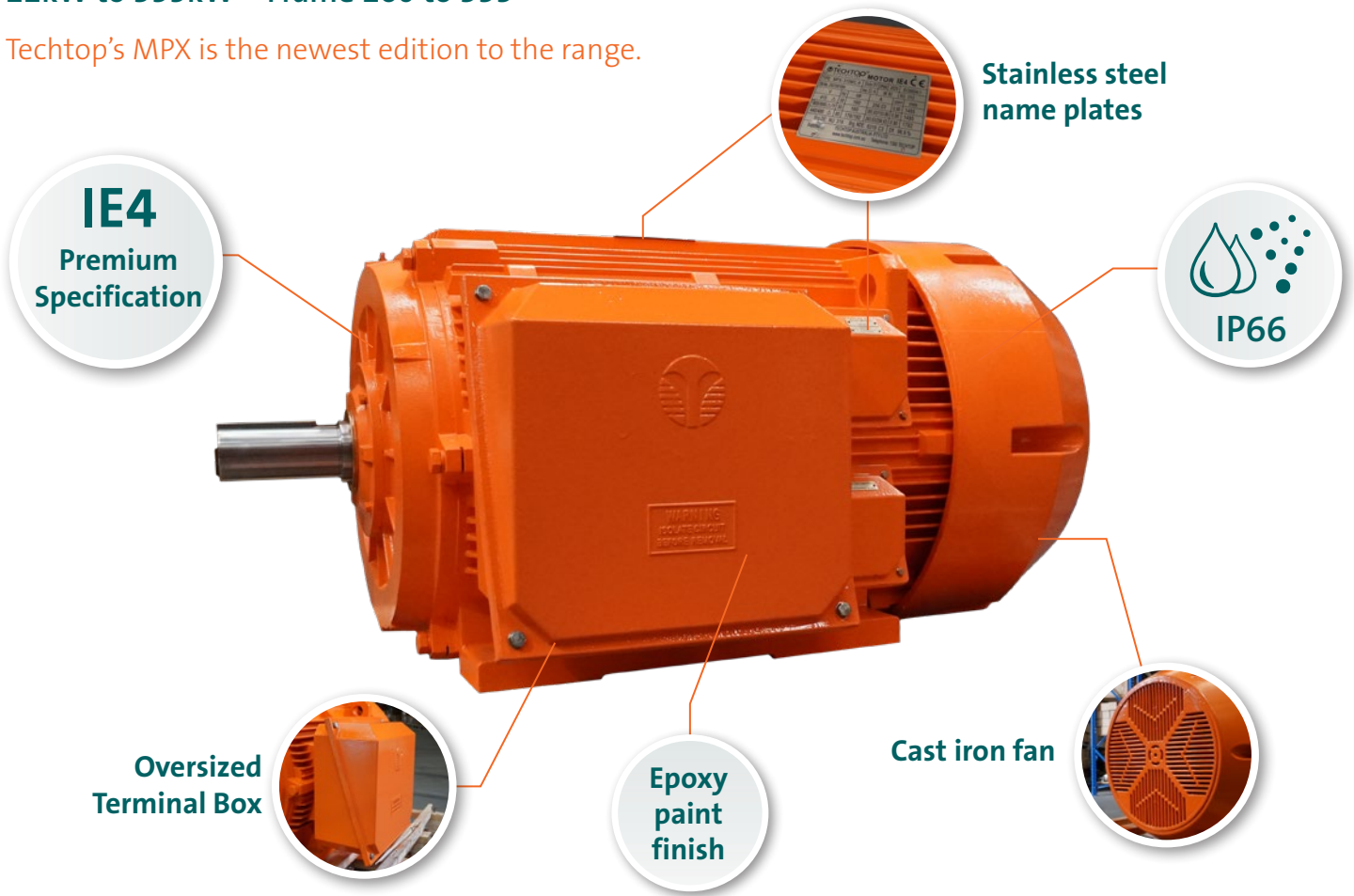

The MPX is an IE4 design and utilizes all of the TCIM features with additional extras as standard.

These features as detailed below:

- IP66 protection
- Class H insulation with Class B rise
- Oil seals fitted at both ends
- Rotating slinger at both ends
- Cast iron fan
- Cast iron fan cowl
- Sintered bronze porous drain plugs
- Stainless steel name plate
- Epoxy paint finish
- Oversized Terminal Box, for ease of Cable Termination
- INPRO shaft seal
- Tropic Proof

Refer Specification Table on Page 29 for full list of features.

Surface Finish

MPX motors are subject to a two pack epoxy coating system with the final colour being RAL 2008 Bright Red Orange.

Operating parameters

MPX series motors are designed with the following parameters:

- 380V to 415V, 50Hz & 440V to 480V 60Hz supply
- Continuous (S1) duty
- Ambient temperatures up to 50°C
- Installation up to 1000 MASL
- Service factors up to 1.25

Available options

- Insulated bearing & earth brush
- Force ventilation



FEATURES

Specification	Frame Size		
	160 - 200	225 - 280	315 - 355
Class H	✓	✓	✓
IP66	✓	✓	✓
Open Bearings	✓	✓	✓
INPRO Labyrinth seals	✓	✓	✓
Oversized Terminal Box	✓	✓	✓
Auxiliary Terminal Boxes	✓	✓	✓
Alarm Thermistor	✓	✓	✓
Trip Thermistor	✓	✓	✓
Fan - Cast Iron	✓	✓	✓
Cowl - Cast Iron	✓	✓	✓
Porous drain plug	✓	✓	✓
Aux T/Box	✓	✓	✓
Stainless Name Plate	✓	✓	✓
Conduit Entry	✓	✓	X
Steel Gland Plate	X	X	✓
Epoxy Paint	✓	✓	✓
Shaft Material - 4140	✓	✓	✓
Heaters	X	✓	✓
Vibration Stud	✓	✓	✓
Bearing & winding RTD's	X	X	✓

TERMINAL BOX DIMENSIONS

Frame	H (mm)	W (mm)	D (mm)
160	220	240	115
180	220	240	115
200	220	240	115
225	335	345	155
250	335	345	155
280	325	345	155
315	445	470	215
355	530	530	240

AUXILIARY BOX DIMENSIONS

Frame	Size		
	H (mm)	W (mm)	D (mm)
160	104	110	70
180			
200			
225	160	170	95
250			
280			
315			
355			

MPX PERFORMANCE DATA

Output (kW)	Full Load Speed [RPM]	Frame Size	Shaft Dia [mm]	Speed (r/min)	Current @ 400v		Efficiency (%)			Power factor (COS)	Torque				Noise Level dB (A)	Weight Foot Mount (kg)
					Full Load (A)	Locked Rotor (%)	100%	75%	50%		Full Load (Nm)	Locked Rotor (% FLT)	Pull Up (% FLT)	Break Down (% FLT)		
0.75	2880	80A	19	2900	1.62	8.8	83.5	83.6	81.5	0.80	2.5	3.7	2.5	3.5	62	15.4
0.75	1420	80B	19	1450	1.89	7.3	85.7	85.3	82.8	0.67	4.9	3.8	3.5	4.1	56	18.5
0.75	940	90S	24	960	2.08	5.3	82.7	81.6	77.7	0.63	7.5	2.7	2.4	3.2	57	22.9
0.75	690	100LA	28	710	2.16	4.3	78.4	77.9	74.4	0.64	10.1	2.1	2.1	2.8	59	33.7
1.1	2880	80A	19	2910	2.27	10.6	85.2	85.2	83.3	0.82	3.6	4.1	2.8	4.3	62	17.6
1.1	1420	90S	24	1460	2.64	8.8	87.2	87.1	84.4	0.69	7.2	4.3	4.3	5.0	59	22.9
1.1	950	90L	24	960	2.89	5.8	84.5	83.5	80.5	0.65	10.9	3.5	3.2	3.7	57	28
1.1	690	100LA	28	710	3.07	4.4	80.8	80.7	78.1	0.64	14.8	2.3	1.9	2.6	59	35.7
1.5	2880	90S	24	2910	3.09	9.6	86.5	86.5	84.6	0.81	4.9	3.6	2.8	4.0	67	21.1
1.5	1440	90L	24	1455	3.46	9.7	88.2	88.1	86.1	0.71	9.8	5.0	4.5	5.2	59	27.8
1.5	945	100LA	28	965	3.50	6.5	85.9	86.2	84.5	0.72	14.8	2.7	2.0	3.0	61	37.7
1.5	700	112M	28	715	4.16	5.1	82.6	82.3	79.5	0.63	20.0	2.5	2.3	3.0	61	44.3
2.2	2890	90L	24	2900	4.35	10.5	88	88.2	86.9	0.83	7.2	4.5	3.6	4.5	67	26
2.2	1440	100LA	28	1460	4.67	9.5	89.5	89.6	88.2	0.76	14.4	3.5	3.0	4.3	64	37.5
2.2	950	112M	28	970	5.27	7.4	87.4	87.2	85.4	0.69	21.6	3.1	2.6	3.9	64	46.3
2.2	710	132S	38	725	5.87	5.6	84.5	85.5	82.5	0.64	29.0	2.3	2.0	3.0	64	69.3
3	2900	100L	28	2910	5.34	11.0	89.1	89.4	88.4	0.91	9.8	3.7	2.6	3.9	74	38.6
3	1445	100LB	28	1460	6.39	9.9	90.4	89.7	88.1	0.75	19.6	3.9	3.4	4.6	64	40
3	960	132S	38	975	6.88	7.1	88.6	88.7	87.4	0.71	29.4	2.6	1.9	3.3	64	63
3	715	132M	38	725	7.52	6.3	85.9	86	84.2	0.67	39.5	2.5	2.1	3.1	64	77.2
4	2915	112M	28	2930	7.05	10.7	90.0	90.4	89.7	0.91	13.0	3.3	2.5	4.1	77	47.4
4	1440	112M	28	1460	7.92	10.9	91.1	91.0	90.0	0.80	26.2	4.0	3.0	4.5	65	52.9
4	960	132MA	38	975	8.72	7.9	89.5	89.8	88.8	0.74	39.2	2.9	1.8	3.5	68	73.6
4	720	160MA	42	725	9.34	7.9	87.1	87.3	86.9	0.71	52.7	2.0	1.4	2.2	68	98
5.5	2910	132SA	38	2940	9.7	10.5	90.9	90.9	89.5	0.90	17.9	3.4	2.2	4.1	79	65.6
5.5	1460	132SA	38	1470	10.8	11.0	91.9	92.2	91.5	0.80	35.7	3.4	2.1	4.1	71	73.5
5.5	960	132MB	38	975	11.70	8.2	90.5	90.7	89.7	0.75	53.8	3.4	1.8	3.3	68	86.6
5.5	720	160MB	42	730	12.5	8.1	88.3	88.5	88.2	0.72	71.9	2.0	1.4	2.2	68	112
7.5	2920	132SA	38	2940	13.0	10.7	91.7	91.7	90.7	0.91	24.3	3.0	2.2	3.7	79	76.1
7.5	1450	132M	38	1470	14.4	11.0	92.6	92.8	92.2	0.81	48.7	4.4	2.2	4.0	71	88.3
7.5	980	160M	42	970	15.6	8.0	91.3	91.5	91.2	0.76	73.8	2.2	1.6	2.5	73	121
7.5	720	160L	42	730	16.4	7.8	89.3	89.5	89	0.74	98.1	2.0	1.4	2.2	68	130
11	2950	160MA	42	2960	19.3	9.5	92.6	92.8	92.5	0.89	35.5	2.5	1.8	2.8	81	126
11	1470	160M	42	1475	20.5	9.5	93.3	93.5	92.8	0.83	71.2	2.5	1.8	2.8	73	132
11	975	160L	42	975	22.3	8.5	92.3	92.5	92.2	0.77	107.7	2.2	1.6	2.5	73	154
11	730	180L	48	735	23.7	7.9	90.4	90.6	90	0.74	142.9	2.0	1.4	2.2	70	180
15	2950	160MB	42	2960	26.1	9.5	93.3	93.5	93.1	0.89	48.4	2.5	1.8	2.8	81	143
15	1470	160L	42	1475	27.4	9.5	93.9	94.1	92.8	0.84	97.1	2.5	1.8	2.8	73	160
15	980	180L	48	975	29.1	8.5	92.9	93.2	92.8	0.80	146.8	2.2	1.6	2.5	73	194
15	730	200L	55	735	31.7	8.0	91.2	91.4	91	0.75	194.8	2.0	1.4	2.2	73	232
18.5	2950	160L	42	2965	32.0	9.5	93.7	93.9	93.6	0.89	59.6	2.5	1.8	2.8	81	165
18.5	1470	180M	48	1475	33.3	9.5	94.2	94.4	93.6	0.85	119.7	2.5	1.8	2.8	76	184
18.5	980	200LA	55	975	35.7	8.5	93.4	93.6	93.3	0.80	181.1	2.2	1.6	2.5	73	240
18.5	730	225S	60	735	38.8	8.1	91.7	91.9	91.4	0.75	240.2	2.0	1.4	2.2	73	324
22	2950	180M	48	2965	38.0	9.5	94	94.2	93.8	0.89	70.8	2.5	1.8	2.8	83	186
22	1465	180L	48	1475	39.5	9.5	94.5	94.7	93.8	0.85	142.4	2.5	1.8	2.8	76	206
22	980	200LB	55	975	41.8	8.5	93.7	93.9	93.6	0.81	215.4	2.2	1.6	2.5	73	264
22	740	225M	60	740	45.4	8.3	92.1	92.3	92	0.76	283.8	2.0	1.4	2.2	73	350



MPX PERFORMANCE DATA CONTINUED

Output (kW)	Full Load Speed [RPM]	Frame Size	Shaft Dia [mm]	Speed (r/min)	Current @ 400v		Efficiency (%)			Power factor (COS ϕ)	Torque				Noise Level dB (A)	Weight Foot Mount (kg)
					Full Load (A)	Locked Rotor (%)	100%	75%	50%		Full Load (Nm)	Locked Rotor (% FLT)	Pull Up (% FLT)	Break Down (% FLT)		
30	2955	200LA	55	2970	51.5	9.0	94.5	94.7	94.3	0.89	96.4	2.5	1.8	2.8	84	246
30	1480	200L	55	1480	53.7	9.0	94.9	95.2	94	0.85	193.5	2.5	1.8	2.8	76	268
30	985	225M	60	980	56.1	8.3	94.2	94.4	94	0.82	292.2	2.2	1.6	2.5	74	348
30	740	250M	65	740	60.7	7.9	92.7	92.9	92.6	0.77	387.0	1.8	1.2	2.0	75	428
37	2955	200LB	55	2970	63.3	9.0	94.8	95	94.7	0.89	118.9	2.5	1.8	2.8	84	270
37	1475	225S	60	1480	66.0	9.0	95.2	95.4	94.6	0.85	238.6	2.5	1.8	2.8	78	330
37	980	250M	65	980	68.1	8.3	94.5	94.7	94.3	0.83	360.4	2.2	1.6	2.5	76	405
37	740	280S	75	740	73.5	7.9	93.1	93.3	93	0.78	477.3	1.8	1.2	2.0	76	528
45	2955	225M	55	2975	76.8	9.0	95	95.2	94	0.89	144.4	2.5	1.8	2.8	86	363
45	1475	225M	60	1480	80.1	9.0	95.4	95.6	95	0.85	290.2	2.5	1.8	2.8	78	370
45	985	280S	75	985	82.5	8.5	94.8	95	94.7	0.83	436.1	2.2	1.6	2.5	78	503
45	740	280M	75	740	89.2	7.9	93.4	93.6	93.3	0.78	580.4	1.8	1.2	2.0	76	603
55	2970	250M	60	2980	93.6	9.0	95.3	95.5	94.3	0.89	176.2	2.0	1.5	2.5	89	441
55	1480	250M	65	1480	96.5	9.0	95.7	95.9	95.3	0.86	354.7	2.0	1.5	2.5	79	471
55	985	280M	75	985	99.4	8.5	95.1	95.3	95	0.84	533.0	2.2	1.6	2.5	78	572
55	740	315S	80	740	105.9	8.2	93.7	93.9	93.4	0.80	709.4	1.8	1.2	2.0	82	976
75	2970	280S	65	2980	127.2	8.5	95.6	95.8	95	0.89	240.2	2.0	1.5	2.5	91	551
75	1480	280S	75	1485	129.6	8.5	96	96.1	95.4	0.87	482.1	2.0	1.5	2.5	80	576
75	980	315S	80	990	135.1	8.0	95.4	95.6	95.3	0.84	723.1	2.2	1.6	2.5	83	803
75	740	315M	80	740	143.6	7.6	94.2	94.5	94	0.80	967.4	1.8	1.2	2.0	82	1120
90	2970	280M	65	2980	152.4	8.5	95.8	95.9	95.2	0.89	288.3	2.0	1.5	2.5	91	658
90	1485	280M	75	1485	153.6	8.5	96.1	96.1	95.8	0.88	578.5	2.0	1.5	2.5	80	671
90	980	315M	80	990	159.9	8.0	95.6	95.8	95.4	0.85	867.7	2.2	1.6	2.5	83	922
90	740	315LA	80	740	169.9	7.7	94.4	94.6	94.2	0.81	1160.9	1.8	1.2	2.0	82	1231
110	2980	315S	65	2980	185.8	8.5	96	96.1	95.6	0.89	352.3	2.0	1.5	2.5	92	904
110	1480	280MB	75	1485	185.2	8.5	96.3	96.3	95.9	0.89	707.0	2.0	1.5	2.5	88	883
110	1485	315S	80	990	195.0	8.0	95.8	96	95.6	0.85	1060.6	2.2	1.6	2.5	83	992
110	980	315LA	80	745	207.0	7.7	94.7	94.9	94.5	0.81	1409.3	1.8	1.2	2.0	82	1265
132	2980	315M	65	2980	222.5	8.5	96.2	96.2	95.7	0.89	422.8	2.0	1.5	2.5	92	1007
132	1485	315M	80	1485	222.1	8.5	96.4	96.4	96.2	0.89	848.4	2.0	1.5	2.5	88	992
132	980	315LB	80	990	230.8	8.0	96	96.2	95.9	0.86	1272.7	2.2	1.6	2.5	83	1078
132	745	355M	100	745	247.9	7.7	94.9	95.2	94.8	0.81	1691.2	1.8	1.2	2.0	89	1573
160	2980	315LA	65	2980	269.5	8.5	96.3	96.3	95.8	0.89	512.5	2.0	1.5	2.5	92	1075
160	1485	315LA	80	1485	265.6	8.5	96.6	96.6	96.3	0.90	1028.4	2.0	1.5	2.5	88	1113
160	985	355MA	100	990	279.1	8.0	96.2	96.3	96	0.86	1542.6	2.2	1.6	2.5	85	1432
160	745	355MB	100	745	296.1	7.7	95.1	95.3	95	0.82	2049.9	1.8	1.2	2.0	89	1656
200	2985	315LB	65	2980	336.1	8.5	96.5	96.5	96	0.89	640.6	2.0	1.5	2.5	92	1228
200	1490	315LB	80	1485	331.7	8.5	96.7	96.7	96.3	0.90	1285.5	2.0	1.5	2.5	88	1246
200	985	355MB	100	990	348.6	8.0	96.3	96.3	96.1	0.86	1928.3	2.2	1.6	2.5	85	1656
200	745	355LB	100	745	369.0	7.8	95.4	95.5	95.2	0.82	2562.4	1.8	1.2	2.0	89	1774
250	2985	355M	75	2980	420.1	8.5	96.5	96.5	96	0.89	800.8	2.0	1.5	2.5	97	1678
250	1490	355M	100	1485	414.6	8.5	96.7	96.7	96.3	0.90	1606.9	2.0	1.5	2.5	92	1491
250	985	355LB	100	990	434.8	8.0	96.5	96.5	96.4	0.86	2410.4	2.2	1.6	2.5	85	1865
315	2985	355LB	75	2980	529.4	8.5	96.5	96.5	96	0.89	1009.0	2.0	1.5	2.5	97	1939
315	1490	355LB	100	1485	522.4	8.5	96.7	96.7	96.4	0.90	2024.7	2.0	1.5	2.5	92	1686

MOUNTING ARRANGEMENTS

Frame Size	B3	B5	B3/B5	V1	V3	V5	V6	B6	B7	B8	V1/V5	V3/V6
80 - 200	✓	✓	✓	✓	✓	✓	✓	✓	✓	✓	✓	✓
225 - 250	✓	✓	✓	✓	-	-	-	-	-	-	-	-
280 - 355	✓	-	✓	✓	-	-	-	-	-	-	-	-

Frame Size	B14	B3/B14	V18	V19	V5/V18	V6/V19
80 - 160	✓	✓	✓	✓	✓	✓

MAXIMUM STARTING TIME (SECONDS)

Frame	Method	2 Pole	4 Pole	6 Pole	8 Pole
80	D.O.L	15	26	40	40
90	D.O.L	10	15	25	30
100	D.O.L	12	14	18	40
112	D.O.L	10	10	18	35
132	D.O.L	14	12	12	25
160-315	D.O.L	15	15	20	22
355	Star-Delta	45	45	60	65

STARTS PER HOUR

Frame	2 Pole	4 Pole	6 Pole	8 Pole
80-90	18	35	40	40
100-132	12	22	25	25
160-180	10	18	22	22
200	6	12	12	12
225	5	10	10	10
250	4	8	8	8
280	3	6	6	8
315	3	4	6	6
355	2	3	3	3



3 PHASE FLAMEPROOF INDUCTION MOTORS

Techtop Australia's TCD YBX3 series of Ex d flameproof motors are certified for use in Zone 1 hazardous areas.



Certification

The full motor range of TCD YBX3 series complies to IEC60079-0:2011 Explosive atmospheres - Part 0 General requirements & IEC60079-1:2014-06 Explosive atmospheres – Part 1: Equipment protected by flameproof enclosure “d”.

The TCD YBX3 range is specially designed and certified for use in Zone 1, Groups IIA & IIB, T4 class temperature, Ex d area. Please note: Group IIC available upon request ex-factory.

This range is certified to IEC/Ex and Atex.

Efficiency

The TCD YBX3 range in 2, 4 & 6 pole complies with MEPS2 requirements of AS/NZS 1359.5:2004 Table A3 (IE3 High Efficiency). Refer GEMS determination 2018.

Motors are tested in accordance with Test Method A of AS/NZS 1359.102.3 as per IEC60034-2-1.

Specification and Operating Parameters

The main dimensions and rated outputs generally conform to IEC60034 and IEC60072.

Motor performance data is designed and based upon:

- S1 continuous running duty
- Ambient temperature standard between -20° C ~ +40° C (Ambient up to 60° C available by output deration).
- Altitudes up to 1000 meters above sea level.
- Standard voltage: 240V/415V, 415V/720V
- Optional voltages: 220V/380V, 230V/400V, 380V/600V, 400V/690V, 660V/1140V 50Hz/60Hz.
- IP66 protection enclosure
- Class F insulation with class B temperature rise

Motor Construction

- Stator and terminal box are manufactured from close-grained pearlitic grey cast iron having 250MPa tensile strength.
- Stator windings are wound with polyester enamel wire of high strength and treated with VPI (vacuum-pressure impregnation) varnish.
- Rotors are of cast aluminum and dynamically balanced.
- Stator and rotor cores are laminated with high-class electrical steel sheet of high permeability.
- Frame size 132 and below, shielded ball bearings are used and fitted with a wave washer at the drive-end.
- Frame size 160 and above are fitted with re-greaseable bearings, inner and outer caps are used to prevent any axial movement.
- Frame size 250 and above have a provision for mounting bearing temperature monitoring devices.
- Motors are fitted with anti-static plastic fan.
- Motors for vertical shaft down application are generally fitted with a rain canopy.

Terminal Box

TCD YBX3 series are designed with a square box arrangement and have excellent flameproof protection.

Motors as standard have 2 conduit entries, 1 x main entry & 1 x thermistor entry, both entries are fitted as standard with IEC/Ex approved cable glands.

Bearings & Grease

All motors up to and including 280 frame are fitted with deep groove ball bearings with 80 to 132 frame being shielded type, 160 and above being open re-greaseable type.

All 4/6/8 pole motors in frames 315 and above are fitted with a roller bearing at the drive end, 2 pole motors are fitted with deep groove ball bearings.

We recommend lithium-based grease, please remove the grease plug located at the bottom of the bearing cap at the drive end and at the bottom of the fan cowl at non-drive end prior to greasing, both grease plugs **must** be replaced after greasing.

Frame Size	Pole	DE Bearing	NDE Bearing
80	2~8P	6204 2RS C3	6204 2RS C3
90	2~8P	6205 2RS C3	6205 2RS C3
100	2~8P	6206 2RS C3	6206 2RS C3
112	2~8P	6206 2RS C3	6206 2RS C3
132	2~8P	6208 2RS C3	6208 2RS C3
160	2~8P	6209 C3	6209 C3
180	2P	6211 C3	6211 C3
	4~8P	6311 C3	6211 C3
200	2P	6212 C3	6212 C3
	4~8P	6312 C3	6212 C3
225	2P	6312 C3	6312 C3
	4~8P	6313 C3	6312 C3
250	2P	6313 C3	6312 C3
	4~8P	6314 C3	6313 C3
280	2P	6314 C3	6314 C3
	4~8P	6317 C3	6314 C3
315	2P	6316 C3	6316 C3
	4~8P	NU319C3	6319 C3
355	2P	6319 C3	6319 C3
	4~8P	NU322C3	6319 C3

Electrical Connections and Thermistors

Motor frame	Connection	Thermistor
80 ~ 132	6 terminals for Star / Delta starting	Optional
160 ~ 355	6 terminals for Star / Delta starting	Fitted

Note: If star / delta starting is required for frame 132 and below, no thermistor is fitted.

Conduit Sizes

Motor frame	Main conduit (X)	Auxiliary conduit (X)
80 ~ 112	1 x M25	1 x M20
132 ~ 180	1 x M40	1 x M20
200 ~ 225	1 x M50	1 x M20
250 ~ 355	1 x M63	1 x M20

Paint

Motors are painted with a high-quality alkyd enamel finish in Carmine Red (RAL 3002), the thickness range is between 80 ~ 100 micron.

Options

- ☛ Suitable for higher ambient temperatures based on deration of kW output.
- ☛ Fitting of anti-condensation heaters.
- ☛ Fitting of extended leads from main terminal box.
- ☛ Suitable for use with VVVF drive based on fitting of 120°C thermistors.
- ☛ Force ventilation by fitment of IEC/Ex approved kit.



TCD YBX3 SERIES PERFORMANCE DATA

IE3 Performance Data 415V/3Ph/50Hz
Class F, IP66, T4 class surface temperature

KW	Motor Frame	Shaft (mm)	Speed RPM	Current (415V)		Efficiency %	Power factor (cosφ)	Full Load (Nm)	Locked Rotor Tst/TN	Break Down Tmax/TN	400V	380V	Moment of inertia J=½GD² (kg m²)	Weight of foot mount motor (Kgs)	Noise Level	Vibration
				Full Load Current (A)	Full Load Current (A)						No Load @ 1 Metre dB(A)	No Load mm/s				
3000 RPM = 2 Pole																
0.75	80A	19	2885	1.66	7.5	80.7	0.78	2.48	2.5	2.8	1.72	1.81	0.0010	29	64	1.3
1.1	80B	19	2885	2.28	8.2	82.7	0.81	3.64	2.7	3.0	2.37	2.50	0.0013	31	64	1.3
1.5	90S	24	2885	3.06	8.8	84.2	0.81	4.97	3.7	3.4	3.17	3.34	0.0020	36	68	1.3
2.2	90L	24	2890	4.24	9.2	85.9	0.84	7.27	3.2	3.1	4.40	4.63	0.0026	40	68	1.3
3	100L	28	2895	5.51	8.7	87.1	0.87	9.90	2.8	3.0	5.71	6.02	0.0044	50	71	1.3
4	112M	28	2895	7.18	8.3	88.1	0.88	13.2	2.6	2.9	7.4	7.84	0.0060	67	71	1.3
5.5	132SA	38	2920	10.0	8.0	89.2	0.86	18.0	2.5	2.9	10.3	10.9	0.0140	85	75	1.3
7.5	132SB	38	2915	13.0	8.1	90.1	0.89	24.6	2.3	3	13.5	14.2	0.0162	89	75	1.3
11	160MA	42	2945	18.9	7.9	91.2	0.89	35.7	2.6	3	19.6	20.6	0.0525	152	79	1.8
15	160MB	42	2945	25.5	8.5	91.9	0.89	48.6	2.9	3	26.5	27.9	0.0608	164	79	1.8
18.5	160L	42	2940	31.3	8.1	92.4	0.89	60.1	3.0	2	32.5	34.2	0.0696	177	79	1.8
22	180M	48	2960	37.1	9.6	92.7	0.89	71.0	3.4	3.1	38.5	40.5	0.0864	240	84	1.8
30	200LA	55	2965	52.0	8.3	93.3	0.86	96.6	2.8	2.9	54.0	56.8	0.1630	289	86	1.8
37	200LB	55	2965	62.4	7.7	93.7	0.88	119.2	2.6	2.9	64.8	68.2	0.1720	307	86	1.8
45	225M	55	2965	74.8	8.9	94.0	0.89	144.9	2.8	2.9	77.6	81.7	0.3562	378	88	1.8
55	250M	60	2965	91.2	9.6	94.3	0.89	177.2	2.6	3.0	94.6	99.6	0.4590	529	88	1.8
75	280S	65	2980	125.2	8.2	94.7	0.88	240.4	2.5	2.8	129.9	136.7	1.007	645	90	1.8
90	280M	65	2970	149.8	8.6	95.0	0.88	289.4	2.8	2.9	155.4	163.6	1.059	701	90	1.8
110	315S	65	2980	180.6	6.8	95.2	0.89	352.5	2.3	2.6	187.4	197.3	1.386	1075	91	2.3
132	315M	65	2980	216.3	6.5	95.4	0.89	423.0	2.0	2.6	224.4	236.2	1.709	1182	91	2.3
160	315LA	65	2980	261.6	8.1	95.6	0.89	512.8	2.8	3.2	271.4	285.7	1.740	1303	93	2.3
200	315LB	65	2980	326.3	7.5	95.8	0.89	640.9	2.4	2.7	338.6	356.4	2.141	1525	93	2.3
250	355MB	75	2980	407.9	7.1	95.8	0.89	801.2	1.8	2.2	423.2	445.5	4.02	1840	100	2.3
315	355LB	75	2980	514.0	7.1	95.8	0.89	1009.5	1.8	2.2	533.3	561.3	4.86	2060	100	2.3

TCD YBX3 SERIES PERFORMANCE DATA

IE3 Performance Data 415V/3Ph/50Hz
Class F, IP66, T4 class surface temperature

KW	Motor Frame	Shaft (mm)	Speed RPM	Current (415V)		Efficiency %	Power factor (cosφ)	Full Load (Nm)	Locked Rotor Tst/TN	Break Down Tmax/TN	400V	380V	Moment of inertia J=½GD² (kg m²)	Weight of foot mount motor (Kgs)	Noise Level	Vibration
				Full Load Current (A)	Full Load Current (A)						No Load @ 1 Metre dB(A)	No Load mm/s				
1500 RPM = 4 Pole																
0.55	80A	19	1435	1.31	6.3	79.0	0.74	3.66	2.3	2.3	1.36	1.43	0.0016	29	58	1.3
0.75	80B	19	1435	1.81	6.2	82.5	0.70	4.99	2.4	2.7	1.87	1.97	0.0020	30	58	1.3
1.1	90S	24	1435	2.49	6.6	84.1	0.73	7.32	2.3	2.7	2.59	2.72	0.0030	37	61	1.3
1.5	90L	24	1440	3.35	6.4	85.3	0.73	9.95	2.6	3.0	3.48	3.66	0.0038	40	61	1.3
2.2	100LA	28	1455	4.65	8.0	86.7	0.76	14.4	2.5	3.0	4.82	5.07	0.0077	51	64	1.3
3	100LB	28	1455	5.95	7.6	87.7	0.80	19.7	2.6	3.0	6.17	6.50	0.0093	56	64	1.3
4	112M	28	1455	8.26	8.6	88.6	0.76	26.3	2.6	2.8	8.57	9.03	0.1280	72	65	1.3
5.5	132S	38	1460	10.8	8.6	89.7	0.79	36.0	2.3	2.7	11.2	11.8	0.0295	90	67	1.3
7.5	132M	38	1460	14.6	8.3	90.4	0.79	49.1	2.4	2.9	15.2	16.0	0.0366	102	67	1.3
11	160M	42	1470	20.4	8.1	91.4	0.82	71.5	2.1	2.6	21.2	22.3	0.0795	148	71	1.8
15	160L	42	1470	27.6	8.9	92.1	0.82	97.4	2.4	2.8	28.7	30.2	0.1034	168	71	1.8
18.5	180M	48	1475	32.3	8.1	92.6	0.86	119.8	2.6	3.0	33.5	35.3	0.1596	221	73	1.8
22	180L	48	1475	38.3	8.8	93.0	0.86	142.4	2.6	2.9	39.7	41.8	0.2025	296	73	1.8
30	200L	55	1480	51.9	7.9	93.6	0.86	193.6	2.6	3.1	53.8	56.6	0.3283	379	75	1.8
37	225S	60	1485	63.7	8.1	93.9	0.86	237.9	2.4	3.0	66.1	69.6	0.4840	409	75	1.8
45	225M	60	1485	77.3	7.6	94.2	0.86	289.4	2.4	2.8	80.2	84.4	0.5653	507	75	1.8
55	250M	65	1480	94.1	8.9	94.6	0.86	354.9	2.7	3.1	97.6	102.7	0.8761	699	77	1.8
75	280S	75	1490	127.7	7.4	95.0	0.86	480.7	2.4	2.8	132.5	139.5	1.954	724	80	1.8
90	280M	75	1490	151.2	7.7	95.2	0.87	576.8	2.6	3.0	156.8	165.1	2.351	756	80	1.8
110	315S	80	1490	182.3	6.7	95.4	0.88	705.0	2.2	3.0	189.1	199.1	2.378	1098	83	2.3
132	315M	80	1490	215.8	6.6	95.6	0.89	846.0	2.0	2.2	223.9	235.7	2.656	1150	85	2.3
160	315LA	80	1490	261.1	6.7	95.8	0.89	1025.5	2.1	2.7	270.9	285.1	2.997	1274	86	2.3
200	315LB	80	1490	326.0	6.7	95.9	0.89	1281.9	1.9	2.6	338.2	356.0	4.123	1566	88	2.3
250	355MB	95	1488	407.1	6.9	96.0	0.89	1604.5	2.3	2.7	422.3	444.6	7.920	2006	91	2.3
315	355LB	95	1488	507.2	6.1	96.0	0.90	2021.7	1.9	2.4	526.2	553.9	7.815	2203	91	2.3



TCD YBX3 SERIES PERFORMANCE DATA

IE3 Performance Data 415V/3Ph/50Hz
Class F, IP66, T4 class surface temperature

KW	Motor Frame	Shaft (mm)	Speed RPM	Current (415V)		Efficiency %	Power factor (cosφ)	Full Load (Nm)	Locked Rotor Tst/TN	Break Down Tmax/TN	400V	380V	Moment of inertia J=½GD² (kg m²)	Weight of foot mount motor (Kgs)	Noise Level	Vibration
				Full Load Current (A)	Full Load Current (A)						No Load @ 1 Metre dB(A)	No Load mm/s				

1000 RPM = 6 Pole

0.75	90S	24	950	2.07	5.6	78.9	0.64	7.54	2.1	2.4	2.14	2.26	0.0038	35	57	1.3
1.1	90L	24	950	2.82	5.9	81.0	0.67	11.1	2.1	2.3	2.93	3.08	0.0053	40	57	1.3
1.5	100L	28	955	3.51	6.4	82.5	0.72	15.0	2.5	2.7	3.64	3.84	0.0107	48	61	1.3
2.2	112M	28	955	4.91	6.4	84.3	0.74	22.0	2.6	2.9	5.09	5.36	0.0151	62	65	1.3
3	132S	38	975	6.87	6.8	85.6	0.71	29.4	1.9	2.3	7.12	7.50	0.0318	87	69	1.3
4	132MA	38	975	9.16	7.6	86.8	0.70	39.2	2.2	2.5	9.50	10.0	0.0394	95	69	1.3
5.5	132MB	38	975	12.6	7.8	88.0	0.69	53.9	2.2	2.6	13.1	13.8	0.0404	103	69	1.3
7.5	160M	42	980	15.0	7.3	89.1	0.78	73.1	2.3	2.8	15.6	16.4	0.0964	147	73	1.8
11	160L	42	980	22.0	6.8	90.3	0.78	107.2	2.3	2.6	22.8	23.7	0.1270	175	73	1.8
15	180L	48	980	28.5	7.8	91.2	0.81	146.2	2.2	2.7	29.6	30.9	0.2010	230	73	1.8
18.5	200LA	55	980	34.8	6.5	91.7	0.81	180.3	2.1	2.7	36.1	37.8	0.3250	281	76	1.8
22	200LB	55	980	38.4	6.7	92.2	0.87	212.4	2.3	2.7	41.8	41.7	0.371	284	76	1.8
30	225M	60	980	55.9	6.7	92.9	0.81	292.3	2.3	2.7	58.0	60.6	0.547	360	76	1.8
37	250M	65	990	66.8	7.4	93.3	0.83	356.9	2.4	3.3	69.3	72.6	0.961	482	78	1.8
45	280S	75	990	79.9	7.6	93.7	0.84	434.1	2.3	3.0	82.9	86.9	1.850	589	80	1.8
55	280M	75	990	97.2	8.3	94.1	0.84	530.6	2.7	3.3	100.9	105.7	2.120	655	80	1.8
75	315S	80	995	130.5	7.3	94.6	0.85	719.8	2.2	3.1	135.3	141.7	2.610	1074	85	2.3
90	315M	80	995	161.4	7.5	94.9	0.82	863.8	2.4	3.3	167.5	175.7	3.040	1170	85	2.3
110	315LA	80	995	189.7	7.3	95.1	0.85	1055.8	2.5	3.0	196.8	206.8	3.710	1295	85	2.3
132	315LB	80	995	229.9	8.1	95.4	0.84	1266.9	2.6	3.4	238.5	250.3	4.240	1450	85	2.3
160	355MA	95	995	277.8	7.1	95.6	0.84	1535.7	1.7	2.5	288.2	302.7	8.359	1861	92	2.3
200	355MB	95	995	333.8	6.7	95.8	0.87	1919.6	1.9	2.5	#REF!	364.6	9.464	1889	92	2.3
250	355LB	95	995	417.3	6.7	95.8	0.87	2399.5	1.8	3.1	433.0	455.7	11.22	2171	92	2.3

TCD YBX3 SERIES PERFORMANCE DATA

IE2 Performance Data 415V/3Ph/50Hz
Class F, IP66, T4 class surface temperature

KW	Motor Frame	Shaft (mm)	Speed RPM	Current (415V)		Efficiency %	Power factor (cosφ)	Full Load (Nm)	Locked Rotor Tst/TN	Break Down Tmax/TN	400V	380V	Moment of inertia J=½GD² (kg m²)	Weight of foot mount motor (Kgs)	Noise Level	Vibration
				Full Load Current (A)	Full Load Current (A)						Full Load Current (A)	No Load @ 1 Metre dB(A)			No Load mm/s	

750 RPM = 8 Pole

2.2	132S	38	710	5.46	6.0	79.0	0.71	29.6	1.8	2.0	5.66	5.96	0.0307	83	65	1.3
3	132M	38	710	7.15	6.0	80.0	0.73	40.4	1.8	2.3	7.41	7.81	0.0426	94	69	1.3
4	160MA	42	720	9.31	6.0	81.9	0.73	53.1	1.9	2.5	9.66	10.2	0.0635	132	70	1.3
5.5	160MB	42	720	12.3	6.0	83.8	0.74	73.0	1.9	2.3	12.8	13.5	0.0897	144	70	1.3
7.5	160L	42	720	16.3	6.0	85.3	0.75	99.5	1.9	2.3	16.9	17.8	0.1270	166	71	1.8
11	180L	48	720	23.9	6.5	86.9	0.75	145.9	2.0	2.2	24.8	25.6	0.2138	223	72	1.8
15	200L	55	730	31.6	6.6	88.0	0.76	196.2	2.1	2.3	32.8	34.1	0.3588	279	73	1.8
18.5	225S	60	740	38.5	6.6	88.6	0.76	238.8	1.9	2.1	39.9	41.7	0.5488	332	74	1.8
22	225M	60	740	44.3	6.6	89.1	0.78	212.4	1.9	2.2	41.8	48.1	0.6454	363	74	1.8
30	250M	65	740	59.3	6.5	89.8	0.79	387.2	2.0	2.1	61.5	64.3	0.9876	478	76	1.8
37	280S	75	740	72.6	6.6	90.3	0.79	477.5	1.9	2.2	75.3	78.8	1.7092	585	78	1.8
45	280M	75	740	87.8	6.6	90.7	0.79	580.7	2.0	2.3	91.1	95.4	1.9875	648	78	1.8
55	315S	80	745	104.2	6.6	91.0	0.81	705.0	1.8	2.0	108.1	113.4	3.9597	972	80	1.8
75	315M	80	745	141.6	6.2	91.6	0.81	961.4	1.8	2.1	146.9	153.6	5.2790	1080	80	2.3
90	315LA	80	750	166.7	6.4	91.9	0.82	1146.0	1.9	2.2	173.0	181.5	6.2695	1226	83	2.3
110	315LB	80	750	203.1	6.4	92.3	0.82	1400.7	1.9	2.0	210.7	220.8	7.4245	1310	83	2.3
132	355S	95	760	242.6	6.4	92.6	0.82	1658.7	1.8	2.1	251.7	264.1	11.427	1405	85	2.3
160	355M	95	760	289.6	6.4	93.0	0.83	2010.5	1.7	2.2	300.5	314.9	13.936	1880	85	2.3
200	355L	95	760	354.8	6.3	94.5	0.83	2513.2	1.9	2.1	374.0	387.4	18.116	2130	86	2.3



TCD YBX3 SERIES DIMENSION DRAWINGS

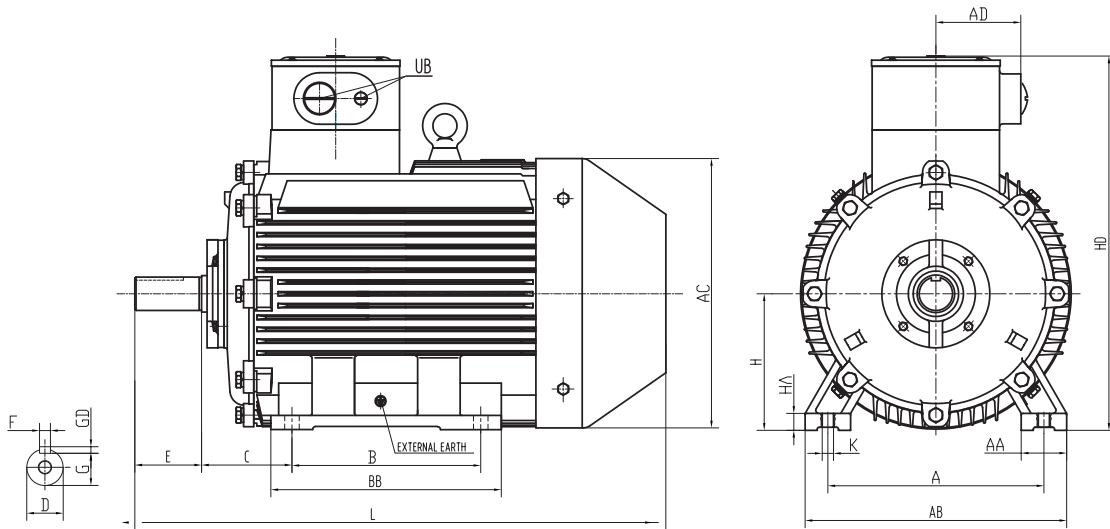

Foot Mount B3

FRAME	A	B	C	D	DB	E	F	G	GD	H	K	AA	AB	AC	AD	BB	HA	HD	L	UB	
80	125	100	50	19	M6	40	6	15.5	6	80	10	34	165	170	100	130	10	320	330	1 x M25	1 x M20
90S	140	100	56	24	M8	50	8	20	7	90	10	36	180	185	100	135	14	330	370	1 x M25	1 x M20
90L	140	125	56	24	M8	50	8	20	7	90	10	36	180	185	100	160	14	330	395	1 x M25	1 x M20
100L	160	140	63	28	M10	60	8	24	7	100	12	43	205	210	100	180	14	360	448	1 x M25	1 x M20
112M	190	140	70	28	M10	60	8	24	7	112	12	50	240	225	125	180	16	380	500	1 x M25	1 x M20
132S	216	140	89	38	M12	80	10	33	8	132	12	60	280	265	125	190	18	430	550	1 x M40	1 x M20
132M	216	178	89	38	M12	80	10	33	8	132	12	60	280	265	125	230	18	430	600	1 x M40	1 x M20
160M	254	210	108	42	M16	110	12	37	8	160	14.5	70	320	320	125	260	20	500	720	1 x M40	1 x M20
160L	254	254	108	42	M16	110	12	37	8	160	14.5	70	320	320	125	310	20	500	750	1 x M40	1 x M20
180M	279	241	121	48	M16	110	14	42.5	9	180	14.5	70	355	360	125	315	25	540	770	1 x M40	1 x M20
180L	279	279	121	48	M16	110	14	42.5	9	180	14.5	70	355	360	125	355	25	540	790	1 x M40	1 x M20
200L	318	305	133	55	M20	110	16	49	10	200	18.5	70	400	400	140	370	25	650	850	1 x M50	1 x M20
225S	356	286	149	60	M20	140	18	53	11	225	18.5	75	435	450	140	360	28	695	890	1 x M50	1 x M20
225M*	356	311	149	55	M20	110	16	49	10	225	18.5	75	435	450	140	385	28	695	920	1 x M50	1 x M20
225M	356	311	149	60	M20	140	18	53	11	225	18.5	75	435	450	140	385	28	695	920	1 x M50	1 x M20
250M*	406	349	168	60	M20	140	18	53	11	250	24	80	500	500	180	430	30	730	965	1 x M63	1 x M20
250M	406	349	168	65	M20	140	18	58	11	250	24	80	500	500	180	430	30	730	965	1 x M63	1 x M20
280S*	457	368	190	65	M20	140	18	58	11	280	24	85	545	550	180	455	35	800	1010	1 x M63	1 x M20
280S	457	368	190	75	M20	140	20	67.5	12	280	24	85	545	550	180	455	35	800	1010	1 x M63	1 x M20
280M*	457	419	190	65	M20	140	18	58	11	280	24	85	545	550	180	505	35	800	1060	1 x M63	1 x M20
280M	457	419	190	75	M20	140	20	67.5	12	280	24	85	545	550	180	505	35	800	1060	1 x M63	1 x M20
315S*	508	406	216	65	M20	140	18	58	11	315	28	120	640	630	240	630	45	960	1240	2 x M63	1 x M20
315S	508	406	216	80	M20	170	22	71	14	315	28	120	640	630	240	630	45	960	1270	2 x M63	1 x M20
315M*	508	457	216	65	M20	140	18	58	11	315	28	120	640	630	240	630	45	960	1240	2 x M63	1 x M20
315M	508	457	216	80	M20	170	22	71	14	315	28	120	640	630	240	630	45	960	1270	2 x M63	1 x M20
315L*	508	508	216	65	M20	140	18	58	11	315	28	120	640	630	240	780	45	960	1390	2 x M63	1 x M20
315L	508	508	216	80	M20	170	22	71	14	315	28	120	640	630	240	780	45	960	1420	2 x M63	1 x M20
355S*	610	500	254	75	M20	140	20	67.5	12	355	28	150	740	710	240	710	52	1030	1450	2 x M63	1 x M20
355S	610	500	254	95	M20	170	25	86	14	355	28	150	740	710	240	710	52	1030	1480	2 x M63	1 x M20
355M*	610	560	254	75	M20	140	20	67.5	12	355	28	150	740	710	240	710	52	1030	1450	2 x M63	1 x M20
355M	610	560	254	95	M20	170	25	86	14	355	28	150	740	710	240	710	52	1030	1480	2 x M63	1 x M20
355L*	610	630	254	75	M20	140	20	67.5	12	355	28	150	740	710	240	810	52	1030	1550	2 x M63	1 x M20
355L	610	630	254	95	M20	170	25	86	14	355	28	150	740	710	240	810	52	1030	1580	2 x M63	1 x M20

* 2 Pole Motors Only

TCD YBX3 SERIES DIMENSION DRAWINGS

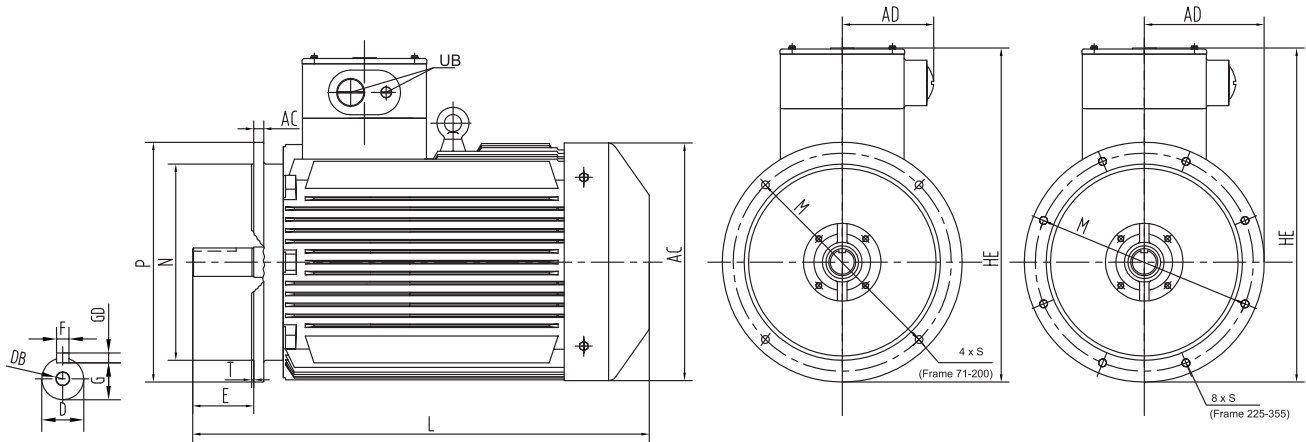

Flange Mount B5

FRAME	D	DB	E	F	G	GD	M	N	P	S	T	AC	AD	HE	LA	L	UB	
80	19	M6	40	6	15.5	6	165	130	200	4 x Ø12	3.5	170	100	340	12	330	1 x M25	1 x M20
90S	24	M8	50	8	20	7	165	130	200	4 x Ø12	3.5	185	100	355	14	370	1 x M25	1 x M20
90L	24	M8	50	8	20	7	165	130	200	4 x Ø12	3.5	185	100	355	14	395	1 x M25	1 x M20
100L	28	M10	60	8	24	7	215	180	250	4 x Ø14.5	4	210	100	400	14	448	1 x M25	1 x M20
112M	28	M10	60	8	24	7	215	180	250	4 x Ø14.5	4	225	125	420	14	500	1 x M25	1 x M20
132S	38	M12	80	10	33	8	265	230	300	4 x Ø14.5	4	265	125	490	14	550	1 x M40	1 x M20
132M	38	M12	80	10	33	8	265	230	300	4 x Ø14.5	4	265	125	490	14	600	1 x M40	1 x M20
160M	42	M16	110	12	37	8	300	250	350	4 x Ø18.5	5	320	125	520	15	720	1 x M40	1 x M20
160L	42	M16	110	12	37	8	300	250	350	4 x Ø18.5	5	320	125	520	15	750	1 x M40	1 x M20
180M	48	M16	110	14	42.5	9	300	250	350	4 x Ø18.5	5	360	125	540	18	770	1 x M40	1 x M20
180L	48	M16	110	14	42.5	9	300	250	350	4 x Ø18.5	5	360	125	540	18	790	1 x M40	1 x M20
200L	55	M20	110	16	49	10	350	300	400	4 x Ø18.5	5	400	140	650	18	850	1 x M50	1 x M20
225S	60	M20	140	18	53	11	400	350	450	8 x Ø18.5	5	450	140	695	18	890	1 x M50	1 x M20
225M*	55	M20	110	16	49	10	400	350	450	8 x Ø18.5	5	450	140	695	18	920	1 x M50	1 x M20
225M	60	M20	140	18	53	11	400	350	450	8 x Ø18.5	5	450	140	695	18	920	1 x M50	1 x M20
250M*	60	M20	140	18	53	11	500	450	550	8 x Ø18.5	5	500	180	755	20	965	1 x M63	1 x M20
250M	65	M20	140	18	58	11	500	450	550	8 x Ø18.5	5	500	180	755	20	965	1 x M63	1 x M20
280S*	65	M20	140	18	58	11	500	450	550	8 x Ø18.5	5	550	180	795	22	1010	1 x M63	1 x M20
280S	75	M20	140	20	67.5	12	500	450	550	8 x Ø18.5	5	550	180	795	22	1010	1 x M63	1 x M20
280M*	65	M20	140	18	58	11	500	450	550	8 x Ø18.5	5	550	180	795	22	1060	1 x M63	1 x M20
280M	75	M20	140	20	67.5	12	500	450	550	8 x Ø18.5	5	550	180	795	22	1060	1 x M63	1 x M20

* 2 Pole Motors Only



TCD YBX3 SERIES DIMENSION DRAWINGS

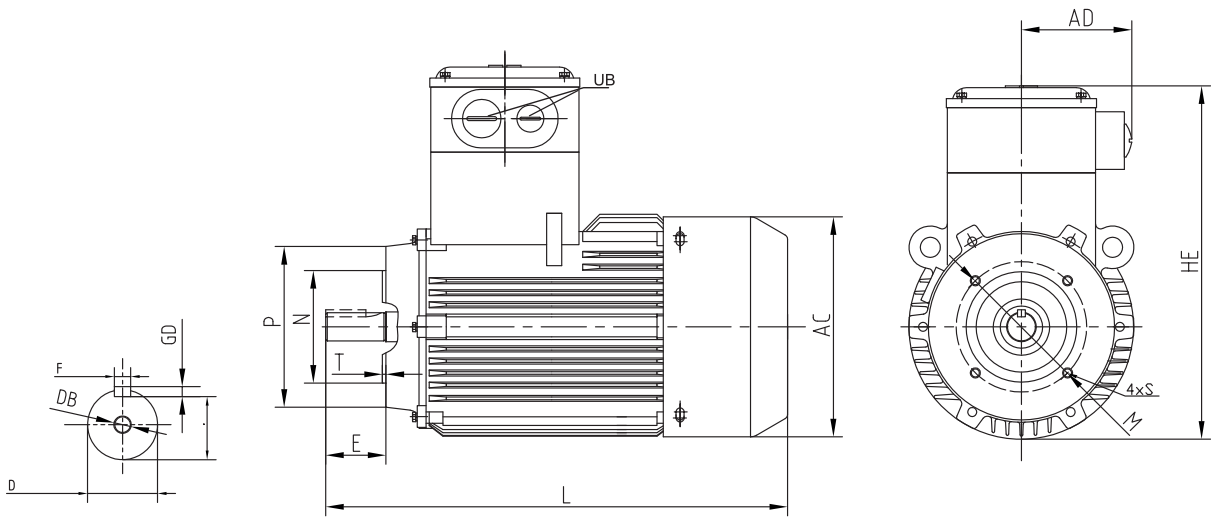

Face Mount B14A

FRAME	D	DB	E	F	G	GD	M	N	P	S	T	AC	AD	HE	LA	L	UB
80	19	M6	40	6	15.5	6	100	80	120	4 X M6	3	170	100	340	12	330	1 x M25 1 x M20
90S	24	M8	50	8	20	7	115	95	140	4 X M8	3	185	100	355	14	370	1 x M25 1 x M20
90L	24	M8	50	8	20	7	115	95	140	4 X M8	3	185	100	355	14	395	1 x M25 1 x M20
100L	28	M10	60	8	24	7	130	110	160	4 X M8	3.5	210	100	400	14	448	1 x M25 1 x M20
112M	28	M10	60	8	24	7	130	110	160	4 X M8	3.5	225	125	420	14	500	1 x M25 1 x M20

IP RATING CHART

First Number	Definition	Second Number	Definition
<i>Protection against solid objects</i>		<i>Protection against liquids</i>	
0	No protection	0	No protection
1	Protected against solid objects over 50mm	1	Protected against vertically falling drops of water
2	Protected against solid objects over 12mm	2	Protected against direct sprays up to 15° from the vertical
3	Protected against solid objects over 2.5mm	3	Protected against direct sprays up to 60° from the vertical
4	Protected against solid objects over 1mm	4	Protected against sprays from all directions - limited ingress permitted
5	Protected against dust - limited ingress (no harmful deposit)	5	Protected against low pressure jets of water from all directions - limited ingress permitted
6	Totally protected against dust	6	Protected against strong jets of water from all directions
		7	Protected against the effects of temporary immersion up to 1 metre
		8	Protected against long periods of immersion under pressure

FORCE VENTILATION KITS

Force ventilation kits purpose made to suit both Aluminium and Cast Iron range.

- Available in both IP55 and IP66

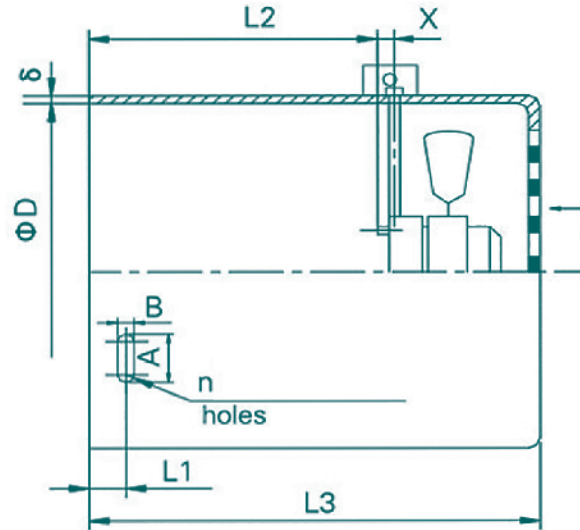

FORCE VENTILATION MOTOR & DIMENSIONAL DATA

Frame	Wattage	M ³ /hour	DIMENSIONS							
			D	L1	L2	L3 - IP55	L3 - IP66	A	B	S
63	20	45	121	13	75	165	193	4	R 3.0	1.2
71	25	52	137	13	90	180	202	4	R 3.0	1.2
80	29	58	157	6	105	195	240	4	R 3.0	1.2
90	32	91	175	7	115	205	245	4	R 3.0	1.2
100	58	142	197	7	120	220	245	4	R 3.0	1.2
112	69	229	218	8	140	240	250	5	R 3.5	1.2
132	52	337	260	8	140	250	292	5	R 3.5	1.5
160	70	609	311	15	165	311	338	6	R 4.5	1.5
180	85	686	357	40	220	340	392	6	R 4.5	1.5
200	105	1679	396	40	230	355	405	6	R 4.5	1.5
225	75	1786	456	35	220	375	430	6	R 4.5	2.0
250	115	1813	504	42	240	397	452	6	R 4.5	2.0
280	180	2415	556	50	260	425	473	9	R 5.5	2.0
315	480	2820	678	55	340	535	570	7	R 6.5	2.0
355	400	3500	694	82	380	585	585	7	R 6.5	2.0

Frame 63 to 355 available in 415/3/50.

Frame 63 to 132 also available in 240/1/50.

VERTICAL HOLLOW SHAFT

Techtop Vertical Hollow Shaft motors are designed to drive deep well turbine water pumps, mainly for irrigation.

They are the smart solution for both standard and high thrust applications.

Available from 15kW to 75kW in 2 pole, and 11kW to 300kW in 4 pole, with a service factor of 1.15.



STAINLESS STEEL MOTORS

Suitable for food, beverage, marine industries and harsh environments.

- IP69K rating for high pressure, high-temperature wash-down applications
- High Efficiency – Equivalent to IE3
- 0.13kW to 18.5kW
- IEC metric frame size
- TEFC or TENV
- Available in B3, B3/5, B3/14A, B3/14B, B5, B14A & B14B mounting arrangements





PHONE 1300 TECH TOP

www.techtop.com.au

AUSTRALIA

VICTORIA HEAD OFFICE

33-35 Gaine Road
Dandenong Sth VIC 3175

P: +61 (0) 3 9753 2222

E: sales@techtop.com.au

QUEENSLAND - BRISBANE

38-42 Quilton Place
Crestmead QLD 4132

P: +61 (0) 7 3106 5111

E: qldsales@techtop.com.au

QUEENSLAND - MACKAY

2/3 Ginger Street
Paget QLD 4740

P: +61 (0) 7 4848 1400

E: mackaysales@techtop.com.au

NEW SOUTH WALES

2/7 Kelham Place
Glendenning NSW 2761

P: +61 (0) 2 9114 6955

E: nswsales@techtop.com.au

SOUTH AUSTRALIA

53 Langford Street
Pooraka SA 5095

P: +61 (0) 8 8829 3088

E: sasales@techtop.com.au

WESTERN AUSTRALIA

1 Kalgan Road
Welshpool WA 6106

P: +61 (0) 8 9908 9111

E: wasales@techtop.com.au

NEW ZEALAND

AUCKLAND

13 Nandina Avenue
East Tamaki, Auckland 2013

Freephone: 0800 48 49 50

P: +64 9 274 7114

E: salesakl@johnbrooks.co.nz

CHRISTCHURCH

120 C Wigram Road,
Wigram, Christchurch 8025

Freephone: 0800 37 38 39

P: +64 3 366 9514

E: saleschc@johnbrooks.co.nz

AUSTRALIAN DISTRIBUTORS – MGP TAS PTY LTD

1 Speedway Drive

Latrobe TAS 7307

P: +61 (0) 3 6441 5236

F: +61 (0) 3 6441 5237

E: sales@mgptas.com.au